

# QUATTRO

## Column Formwork

Instructions for Assembly and Use – Standard Configuration

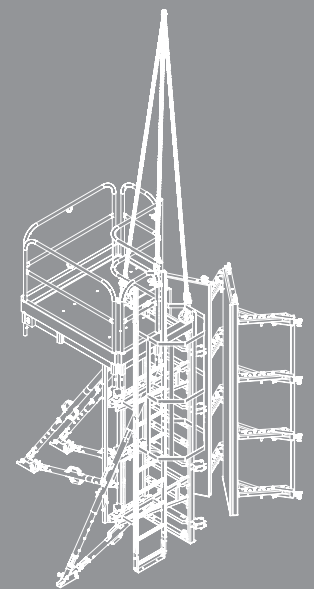

## Main Components

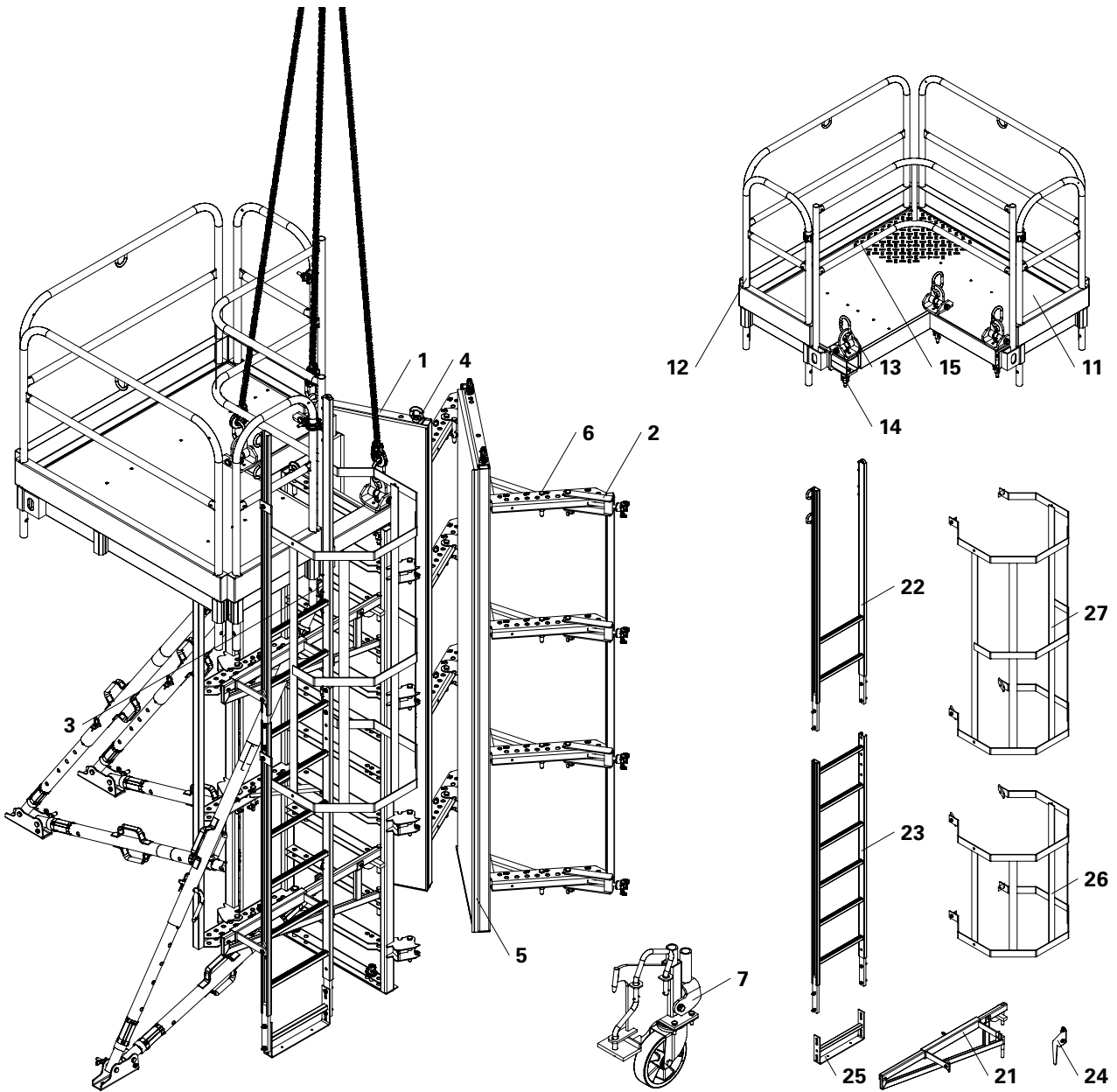

### QUATTRO Column

- 1 QUATTRO Frame QES
- 2 Frame Spanner QUATTRO QA
- 3 Brace Connector QUATTRO QR
- 4 Eyebolt M20 x 110
- 5 Chamfer Strip QDL
- 6 Bolt Ø 20 x 140
- 7 Transportation Wheel QUATTRO

### Concreting Platform, Complete

- 11 Concreting Landing
- 12 Platform Guardrail 134 or 52
- 13 Crane Hook Concreting Platform
- 14 Cam Nut DW 15
- 15 Platform Front Guardrail 86/86

### Access Ladders

- 21 QUATTRO Lader Connector-2
- 22 End Ladder 180/2
- 23 Ladder 180/6
- 24 Ladder Hook
- 25 Ladder Base
- 26 Ladder Safety Cage 75
- 27 Ladder Safety Cage 150

<b>Overview</b>	
Main Components	1
Key	2
Presentational Reference	2
<b>Introduction</b>	
Target Groups	3
Additional Technical Documentation	3
Intended Use	4
Instructions on Use	4
Cleaning and Maintenance Instructions	5
<b>Safety Instructions</b>	
Cross-System	6
System-Specific	7
Storage and Transportation	7
<b>Assembly and Dismantling</b>	
A1 Storage and Transportation	8
Moving on the Construction Site	8
A2 Cleaning	9
A3 Assembly	
Preparation	10
Assembly	11
Extending at the Bottom / Extensions	12
Push-Pull Props	13
Concreting Platform	14
Parts List for Access Ladders	14
Access Ladders	15
A4 Shuttering	
Placing the Formwork	16
Closing the Formwork	17
A5 Striking, Moving	18
A6 Adjusting Column Cross-Section	20
<b>Components</b>	
Components	22

## Key

### Pictogram | Definition

 Safety instructions

 Note

 Load-bearing point

 Visual check

### Dimension specifications

Dimensions are usually given in mm.

Other measurement units, e.g. cm, are shown in the illustrations.

Load details are usually given in kg. Other measurement units, e.g. t, are shown in the illustrations.

### Conventions

- Instructions are numbered with:  
1. ...., 2. ...., 3. ....
- The result of an instruction is shown by: →
- Position numbers are clearly provided for the individual components and are given in the drawing, e.g. 1, in the text in brackets, for example (1).
- Multiple position numbers, i.e. alternative components, are represented with a slash, e.g. 1 / 2.

### Arrows

- ➔ Arrow representing an action
- ⇨ Arrow representing a reaction of an action\*
- ➡ Forces

\* If not identical to the action arrow.

---

## Presentational Reference

The illustration on the front cover of these instructions is understood to be a system representation only. The assembly steps presented in these Instructions for Assembly and Use are shown in the form of examples with only one component size. They are valid accordingly for all component sizes contained in the standard configuration.

For a better understanding, detailed illustrations are partly incomplete. Safety installations may not have been included in these detailed drawings, but must be used nevertheless.

## Target Groups

### Contractors

These Instructions for Assembly and Use are designed for contractors who either

- assemble, modify and dismantle the formwork system, or
- use it, e.g. for concreting, or
- who have it used, e.g. for forming operations.

### Construction site coordinator

The Safety and Health Protection Coordinator\*

- is appointed by the client,
- must identify potential hazards during the planning phase,
- determines measures that provide protection against risks,
- creates a health and safety plan,
- coordinates the protective measures for the contractor and site personnel so that they do not endanger each other,
- monitors compliance with the protective measures.

### Competent persons

Due to the specialist knowledge gained from professional training, work experience and recent professional activity, the competent person has a reliable understanding of safety-related issues and can correctly carry out inspections.

Depending on the complexity of the test to be undertaken, e.g. scope of testing, type of testing or the use of certain measuring devices, a range of specialist knowledge is necessary.

### Qualified persons

The scaffolding may only be assembled, modified or dismantled by personnel who are suitably qualified to do so. For the work to be carried out, the qualified persons must have received instructions\*\* covering at least the following points:

- Explanation of the plan for the assembly, modification or dismantling of the formwork in an understandable form and language.
- Description of the measures for safely assembling, modifying or dismantling the scaffolding.
- Designation of the preventive measures to avoid the risk of persons and objects falling.

- Designation of the safety precautions in the event of changing weather conditions that could adversely affect the safety of the formwork system as well as the persons concerned.
- Details regarding the permissible loads.
- Description of any other risks that are associated with the assembly, modification or dismantling procedures.



- **In other countries, ensure that the relevant national guidelines and regulations in the respective current version are complied with!**
- **If no country-specific regulations are available, it is recommended to proceed according to German guidelines and regulations.**

\* Valid in Germany: Regulations for Occupational Health and Safety on Construction Sites 30 (RAB 30).

\*\* Instructions are given by the contractor himself or a competent person selected by him.

---

## Additional Technical Documentation

- Design Tables 2015 – Formwork and Scaffolding
- Brochures
  - QUATTRO Column Formwork

## Intended Use

### Product description

PERI products have been designed for exclusive use in the industrial and commercial sectors by qualified users only.

PERI QUATTRO is the column formwork designed for fast moving with one crane lift. Units can also be moved by hand using the insertable transportation wheels. In the process, all mounting parts remain attached to the formwork. Concrete surfaces with increased requirements can be realised thanks to the formlining that is installed from the rear. A chamfer strip should be fixed to vertical panel joints. Both square and rectangular column cross-sections can be formed through the formwork element arrangement, which is based on the windmill vane principle.

### Technical data

Permissible fresh concrete pressure 80 kN/m<sup>2</sup>.

### System dimensions

#### Formwork height:

Maximum 4.50 m, extendable in 25-cm increments.

#### Column cross-sections:

Square or rectangular from 20 x 20 cm to 60 x 60 cm in 5-cm increments.

---

## Instructions on Use

Use in a way not intended, deviating from the standard configuration or the intended use according to the Instructions for Assembly and Use, represents a misapplication with a potential safety risk, e.g. risk of falling.

Only PERI original components may be used. The use of other products and spare parts is not allowed.

Changes to PERI components are not permitted.

## Cleaning and Maintenance Instructions

In order to maintain the value and operational readiness of the formwork materials over the long term, clean the panels after each use.

Some repair work may also be inevitable due to the tough working conditions. The following points should help to keep cleaning and maintenance costs as low as possible.

Spray the formwork on both sides with concrete release agent before each use. This allows easier and faster cleaning of the formwork. Spray the concrete release agent very thinly and evenly!

Spray the rear side of the formwork with water immediately after concreting. This avoids any time-consuming and costly cleaning operations.

When used continuously, spray the panel formlining with concrete release agent immediately after striking. Then clean by means of a scraper, brush or rubber lip scraper. Important: do not clean plywood formlining with high-pressure equipment as this could result in the formlining being damaged.

Fix box-outs and mounting parts with double-headed nails. This allows the nails to be removed easily later on, and largely avoids damage to the formlining.

Close all unused anchor holes with plugs. This eliminates any subsequent cleaning or repair work. Anchor holes accidentally blocked with concrete are freed by means of a steel pin from the formlining side.

When placing bundles of reinforcement bars or other heavy objects on horizontally-stored formwork elements, suitable support, e.g. square timbers, is to be used. As a result, impressions and damage to the formlining are largely avoided.

Internal concrete vibrators should be fitted with rubber caps if possible. This reduces any damage to the formlining if the vibrator is accidentally inserted between the reinforcement and formlining.

Never clean powder-coated components, e.g. elements and accessories, with a steel brush or hard metal scraper. This ensures that the powder-coating remains intact.

Use spacers for reinforcement with large-sized supports or extensive areas of support, as this largely avoids impressions being formed in the formlining when under load.

Mechanical components, e.g. spindles or gear mechanisms, must be cleaned of dirt or concrete residue before and after use, and then greased with a suitable lubricant.

Provide suitable support for the components during cleaning so that no unintentional change in their position is possible.

Do not clean components suspended on crane lifting gear.

## Cross-System

### General

The contractor must ensure that the Instructions for Assembly and Use supplied by PERI are available at all times and understood by the site personnel.

These Instructions for Assembly and Use can be used as the basis for creating a risk assessment. The risk assessment is compiled by the contractor. However, these Instructions for Assembly and Use do not replace the risk assessment!

Always take into consideration and comply with the safety instructions and permissible loads.

For the application and inspection of PERI products, the current safety regulations and guidelines valid in the respective countries must be observed.

Materials and working areas are to be inspected on a regular basis, especially before each use and assembly, for:

- signs of damage,
- stability and
- function.

Damaged components must be exchanged immediately on site and may no longer be used.

Safety components are to be removed only when they are no longer required.

Components provided by the contractor must conform with the characteristics required in these Instructions for Assembly and Use as well, as with all valid construction guidelines and standards. Unless otherwise indicated, this applies in particular:

- timber components: strength class C24 for solid wood according to EN 338.
- scaffold tubes: galvanised steel tubes with minimum dimensions of  $\varnothing 48.3 \times 3.2$  mm according to EN 12811-1:2003 4.2.1.2.
- scaffold tube couplings according to EN 74.

Deviations from the standard configuration are only permitted after a further risk assessment has been carried out by the contractor. Appropriate measures for working and operational safety, as well as stability, are defined on the basis of this risk assessment.

Corresponding proof of stability can be provided by PERI on request if the risk assessment and resulting measures to be implemented are made available.

Before and after exceptional occurrences that may have an adverse effect regarding the safety of the formwork system, the contractor must immediately

- create another risk assessment, with appropriate measures for ensuring the stability of the formwork system being carried out based on the results,
- and arrange for an extraordinary inspection by a competent person.

The aim of this inspection is to identify and rectify any damage in good time, in order to guarantee the safe use of the formwork system.

Exceptional occurrences can include:

- accidents,
- longer periods of non-use,
- natural events, e.g. heavy rainfall, icing, heavy snowfall, storms or earthquakes.

### Assembly, modification and dismantling work

Assembly, modification or dismantling of formwork systems may only be carried out by qualified persons and under the supervision of a competent person. The qualified persons must have received appropriate training for the work to be carried out with regard to specific risks and dangers.

On the basis of the risk assessment and the Instructions for Assembly and Use, the contractor must create installation instructions, in order to ensure safe assembly, modification and dismantling of the formwork system.

The contractor must ensure that the personal protective equipment required for the assembly, modification or dismantling of the formwork system, e.g.

- safety helmet,
- safety shoes,
- safety gloves,
- safety glasses,

is available and used as intended.

If personal protective equipment against falling from a height (PPE) is required or specified in local regulations, the contractor must determine appropriate attachment points on the basis of the risk assessment.

The contractor stipulates the PPE to be used to prevent falling.

The contractor must

- provide safe working areas for site personnel, which are to be reached through the provision of safe access ways. Areas of risk must be cordoned off and clearly marked.
- ensure stability during all stages of construction, in particular during assembly, modification and dismantling operations.
- ensure and prove that all loads can be safely transferred.

### Utilisation

Every contractor who uses or allows formwork systems or sections of the formwork to be used, is responsible for ensuring that the equipment is in good condition.

If the formwork system is used successively or at the same time by several contractors, the health and safety coordinator must point out any possible mutual hazards, and all work must be then coordinated.



## System-Specific

Retract components only when the concrete has sufficiently hardened, and the person in charge has given the go-ahead for striking to take place.

Anchoring is to take place only if the anchorage has sufficient concrete strength.

Only use designated PERI lifting gear.

During striking, do not tear off the formwork panels with the crane.

If a storm warning is given, additional push-pull props or other bracing measures are to be used and the details in the PERI design tables must be implemented.

## Storage and Transportation

Store and transport components ensuring that no unintentional change in their position is possible. Detach lifting accessories and slings from the lowered components only if they are in a stable position and no unintentional change is possible.

Do not drop the components.

Use PERI lifting accessories and slings and only those load-bearing points provided on the component.

During the moving procedure

- ensure that components are picked up and set down so that unintentional falling over, falling apart, sliding, falling down or rolling is avoided.
- no persons are allowed to remain under the suspended load.

Always guide pre-assembled scaffolding bays, scaffolding units or scaffolding sections with ropes when moving them by crane.

The access areas on the jobsite must be free of obstacles and tripping hazards, as well as being slip-resistant.

For transportation, the surface used must have sufficient load-bearing capacity.

Use original PERI storage and transport systems, e.g. crate pallets, pallets or stacking devices.

For storing and transporting, lay the four column frames QUATTRO QES on top of each other to form a stack and then store bundled together positioned on timbers.

(Fig. A1.01)

When storing horizontally, a maximum of three stacks are placed on top of each other with timbers placed in between.

The stack can be transported using both a forklift truck and crane.

(Fig. A1.02)

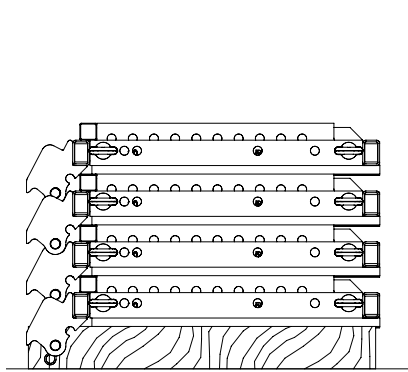

Fig. A1.01

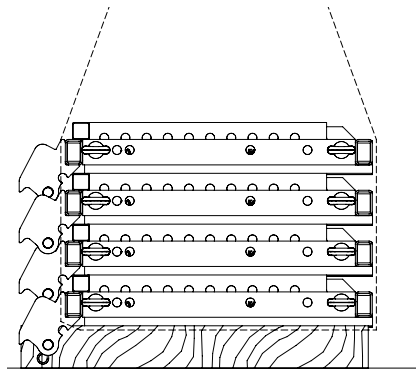

Fig. A1.02

## Moving on the Construction Site

### Unit with concreting platform

Attach the 3-sling lifting gear to the three crane eyes of the concreting platform (13).

(Fig. A1.03)

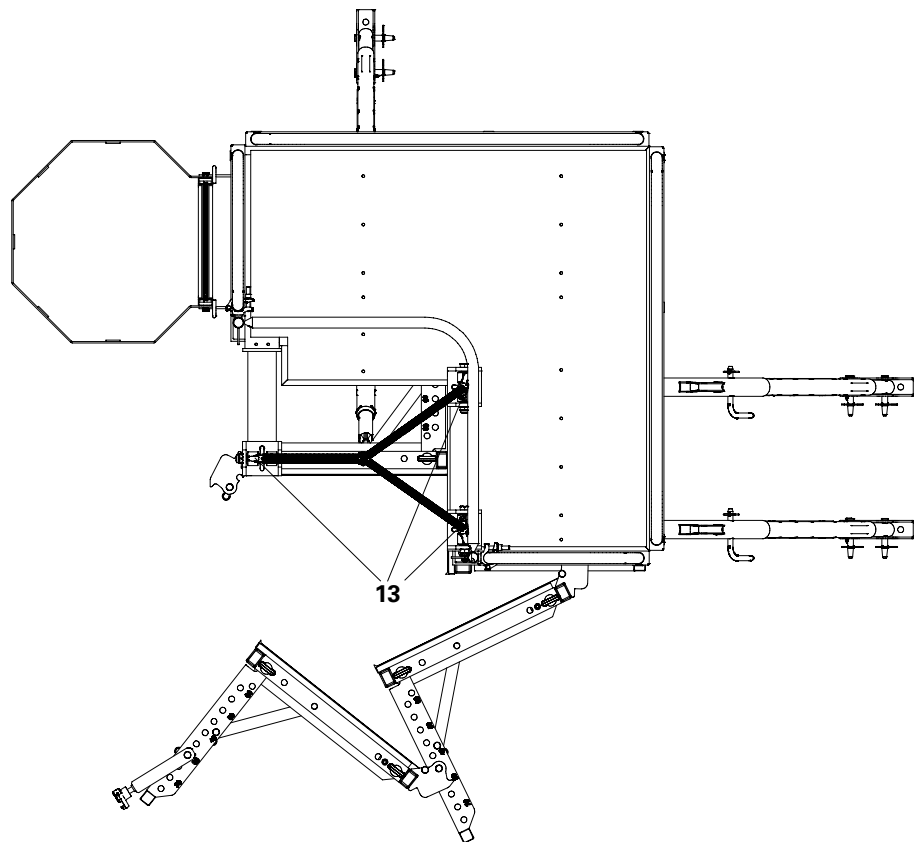

Fig. A1.03

In order to maintain the value and operational readiness of the QUATTRO column formwork for a long period, ensure that the formwork is treated with great care.

### Maintenance instructions

- Concrete vibrators with rubber end caps reduce the risk of damage to the formlining.
- Spray the components with PERI Bio Clean before every use and clean the rear of the formwork with water immediately after concreting.
- Spray moving parts, if required, with PERI Bio Clean.



When cleaning the formlining, do not use items that are scratched or have been damaged through force of any kind!

Cleaning requirements are kept to a minimum thanks to the powder coating.



## Preparation

Before assembly takes place, a Chamfer Strip QDL (5) must be attached to the long side of the formlining. This can be carried out when stacked. (Fig. A3.01)



The Chamfer Strip QDL is fixed with nails at approx. 15-cm spacings.

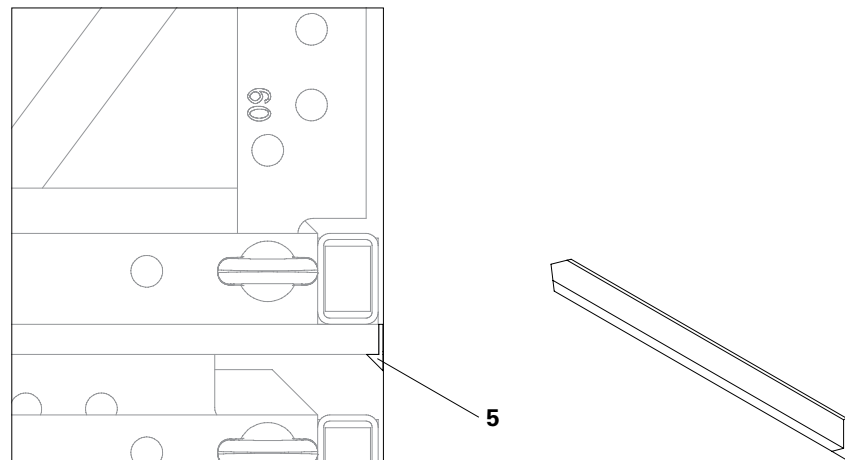

Fig. A3.01

## Assembly

1. With the QUATTRO QES element in a horizontal position, remove bolts  $\text{Ø } 20 \times 140$  (1.3) from the perforated walers (1.1).
2. Swivel out (1.1) the perforated waler and fix the diagonal struts (1.2) in position using the bolts  $\text{Ø } 20 \times 140$  (1.3).
3. Secure with bolts  $\text{Ø } 20 \times 140$  (1.3) and cotter pins 4/1. (Fig. A3.02)

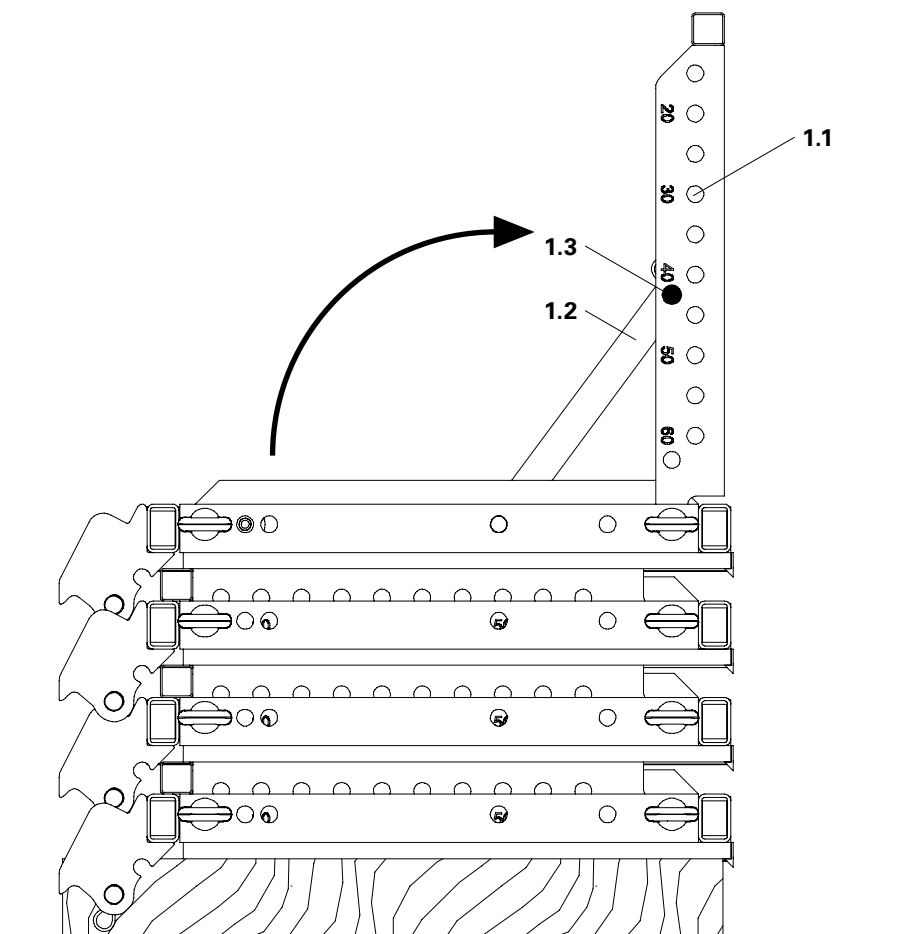

Fig. A3.02

## Assembly

### Assembly

1. Position the first QUATTRO QES Column Frame together with perforated waler (1.1) on the assembly area and remove Bolts  $\varnothing 20 \times 140$  (1.5) from the fastening straps.(Fig. A3.04)
2. Unscrew eye bolts M20 x 110 (4) on the second QUATTRO QES Column Frame and re-attach using the drilled holes (a). (Fig. A3.03)
3. Attach the 2-sling lifting gear to the offset eye bolts M20 x 110 and swivel the QUATTRO QES Column Element to the first QUATTRO QES Column Element using a crane.(Fig. A3.04)
4. Connect both QUATTRO QES Column Elements to the fastening straps and perforated walers by means of Bolts  $\varnothing 20 \times 140$  (1.5) and Cotter Pins 4/1. (Fig. A3.05)



Do not damage the Chamfer Strip QDL. The stamped measurements on the perforated waler indicate the column cross-section.

(Fig. A3.05a)



A wood gauge makes the work easier.

(Fig. A3.04)

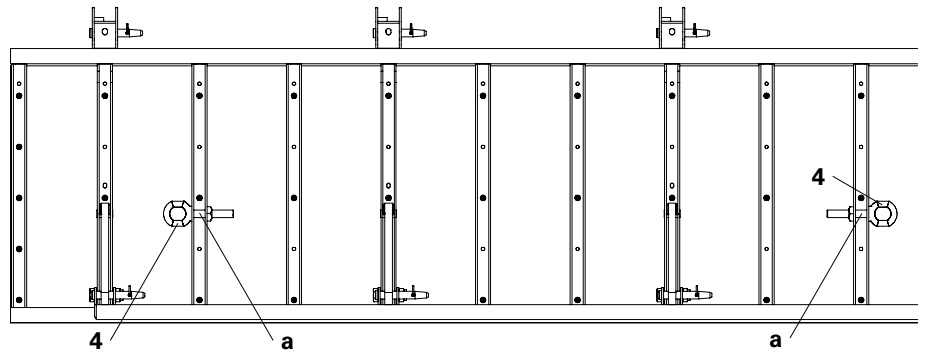

Fig. A3.03

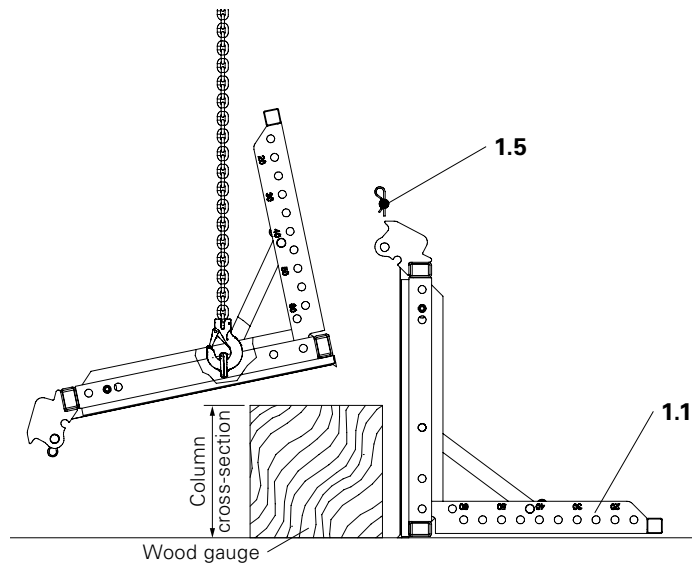

Fig. A3.04

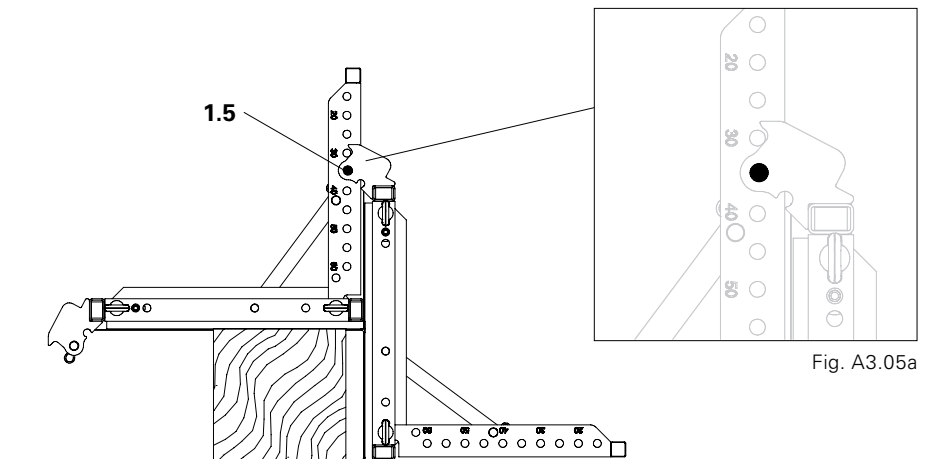

Fig. A3.05

## Extending at the Bottom / Extensions

1. Pre-assemble bottom extension / height extension element: see Assembly.
2. Remove QUATTRO QB Bottom Plate (7) from the QUATTRO QES Column Element and re-attach to the bottom extension.
3. Fix to horizontal base element using eyebolts M20 x 110 (4). (Fig. A3.07)

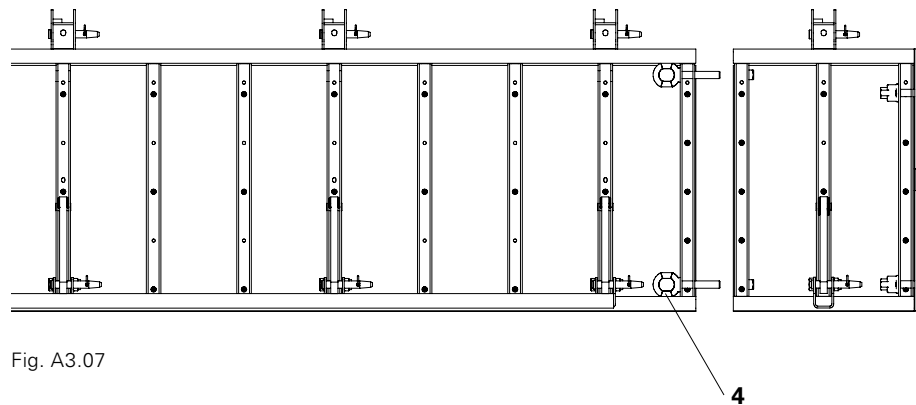

Fig. A3.07



- In order to avoid dismantling and re-assembling the concreting platform and access ladder, the column formwork is to be extended or shortened from below at varying concreting heights.
- Ensure that formlining joints are flush and formlining edges are vertically aligned.

### Table Required panels and push-pull props depending on the formwork height

Formwork height [m]	Panels				Push-Pull Props Kickers	RS Push-Pull Props
	350	275	125	50		
2.50*			2		RSS I - AV	RS300 - RS210
2.75		1			RSS I - AV	RS300 - RS210
3.00*			2	1	RSS I - AV	RS300 - RS210
3.25		1		1	RSS II - AV	RS300 - RS210
3.50***	1				RSS II - AV	RS450 - RS210
3.75**		1		2	RSS II - AV	RS450 - RS210
4.00**	1			1	RSS II - AV	RS450 - RS210
4.50**	1			2	RSS II - AV	RS450 - RS210

\* With these heights, additional bottom plates are to be ordered.

\*\* Permissible fresh concrete pressure 80 kN/m<sup>2</sup>.

\*\*\* permissible fresh concrete pressure 90 kN/m<sup>2</sup>.

## Push-Pull Props



**Mount 3 push-pull props to ensure stability!**

1. Secure the element unit by means of locking bolts  $\text{Ø } 20 \times 140$  (6) in the second perforated strut from the bottom.
2. Mount push-pull prop connections QUATTRO QR (3), push pull props RS and kicker braces AV.

Mount the push-pull props as far as possible to the outside.  
(Fig. A3.08)



One locking bolt  $\text{Ø } 20 \times 140$  is available on the element.

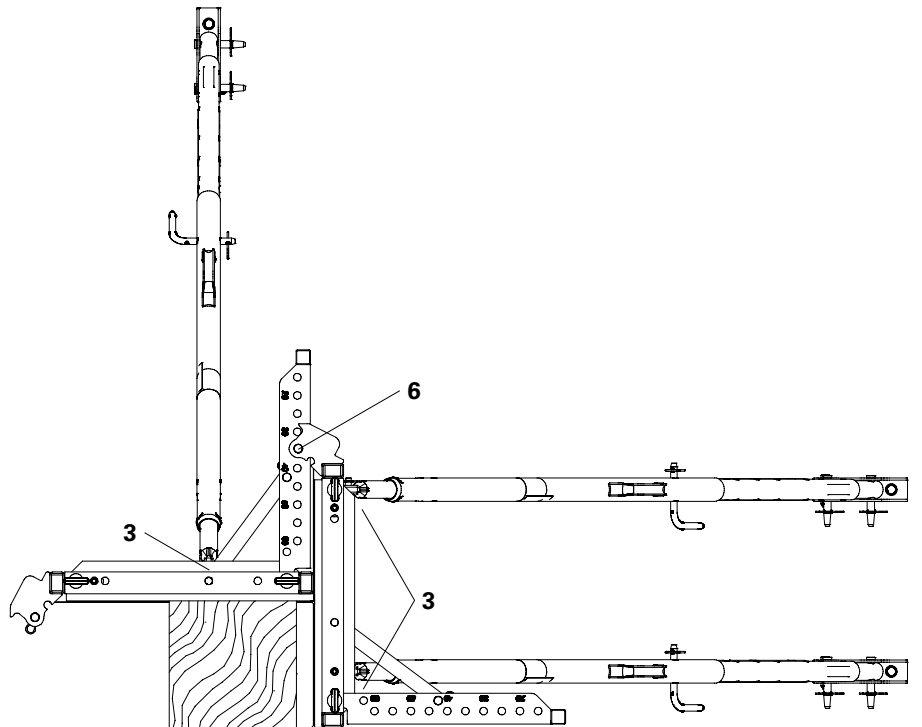

Fig. A3.08

## Concreting Platform

Assembly on the horizontally-positioned formwork half.

1. Remove eye bolt M20 x 110 from the QUATTRO QES Column Element and attach to one of the lower cross struts to ensure that it is not lost.
2. Remove the cam nuts DW 15 (14) from the crane eyes on the concreting platform (13) and position the platform by hand on the element group.
3. Push the crane eye of the concreting platform through the drilled hole (b) of the panel border and undo cam nut DW 15, SW 27. In so doing, slightly raise the concreting platform.
4. Proceed in the same way for drilled hole (c).
5. Align telescopic girder to drilled hole (d) and mount the third crane eye of the concreting platform.(Fig. A3.09)
6. Insert Platform Guardrail (12), Guardrail 134, 2 x, Guardrail 52, 1 x. (Fig. A3.10)

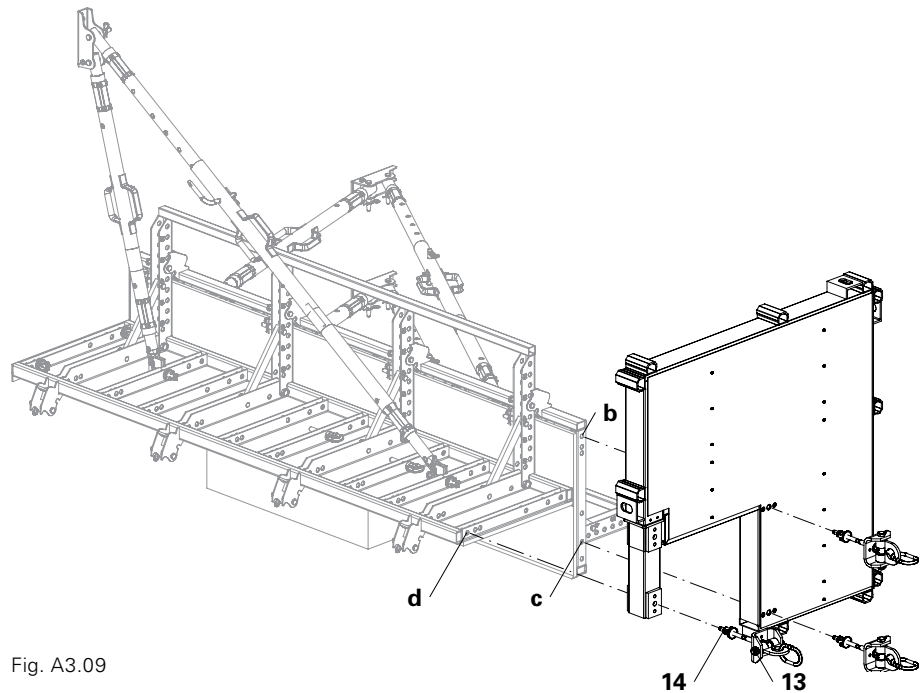

Fig. A3.09



If the drilled holes do not match, then turn the concreting platform by 180°.



**To access the platform, slide the respective end guardrail upwards out of the platform and reinsert it into the designated lugs of the concreting platform immediately after entering.**

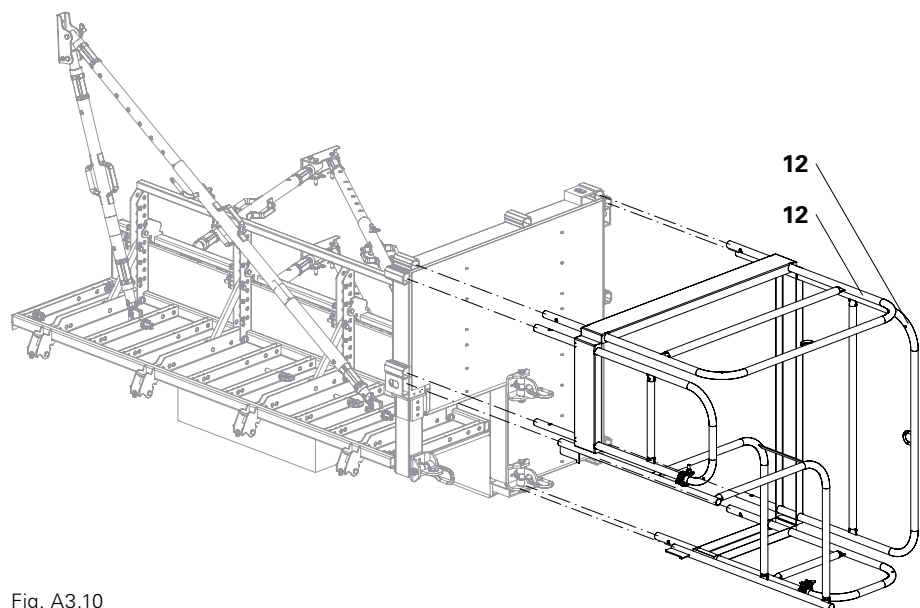

Fig. A3.10

## Parts List for Access Ladders

Item no.	With access ladder Description	2.70 – 3.60 m	3.90 – 4.20 m
037400	Concreting Platform, Complete	1	1
051410	Ladder 180/6	2	2
103724	End Ladder 180/2	1	1
051450	Ladder Safety Cage 150	1	1
104132	Ladder Safety Cage 75	0	1
051460	Ladder Base	1	1
103718	Ladder Hook	2	2
127260	QUATTRO Ladder Connector-2	2	2



## Access Ladders

Assembly on the horizontally-positioned formwork half.

1. Position QUATTRO Ladder Connections-2 (21) on the frame.
2. Insert bolts in the outermost drilled hole and secure with clamp. (Fig. A3.11)
3. Pre-assembling the ladder:
  - attach Ladder 180/6 (23) to Access Ladder 180/2 (22), SW 19.
  - fix ladder base to Ladder 180/6.
4. Adjust distance of the ladder to the platform access point and secure with the eye bolt.
5. Fix Ladders 180/6 and 180/2 with clamping plates (28) to the QUATTRO Ladder Connections-2 (21), SW 19. (Fig. A3.12)
6. Attach Ladder Safety Cage 150 (27) using clamping plates to Access Ladder 180/2 and Ladder 180/6 using an overlapping ladder joint, SW 19. (Fig. A3.13)

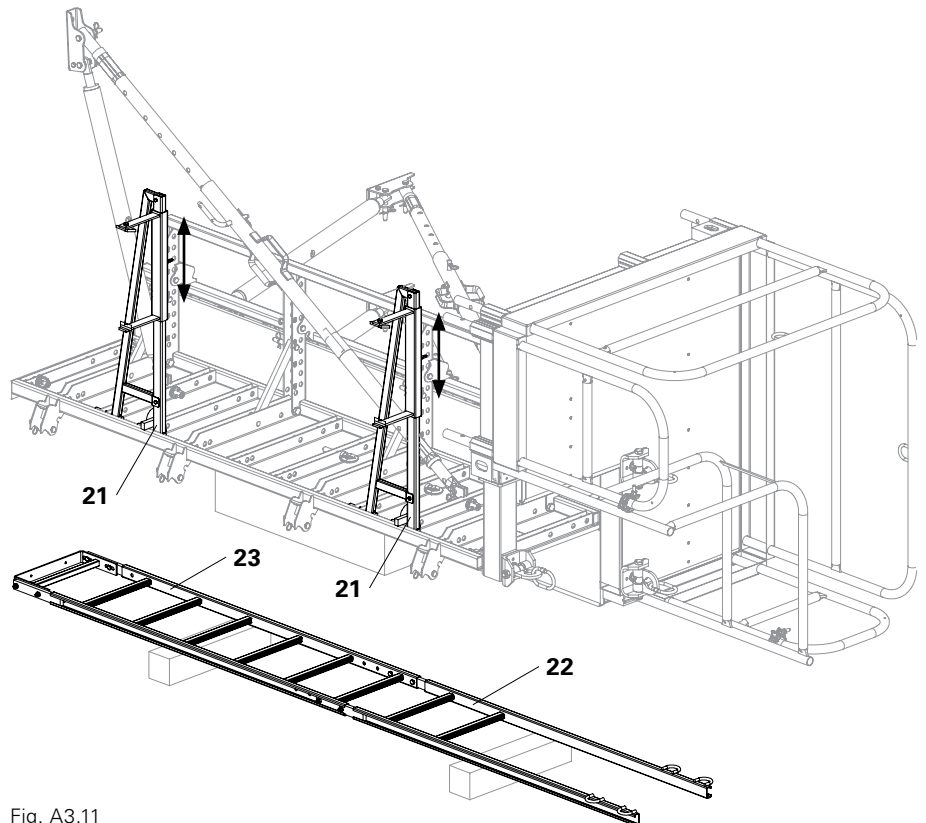

Fig. A3.11

## Assembly at great heights

1. Insert bolts in the outermost drilled hole and secure with clamp.
2. Attach Ladder 180/6 (23) to Access Ladder 180/2 (22), SW 19.
3. Depending on the height, attach additional Ladders 180/6.
4. Mount ladder hooks and ladder base to the bottom-most ladder.
5. Fix Ladders 180/6 and 180/2 with clamping plates (28) to the ladder connections (21), SW 19.
6. Attach Ladder Safety Cage 150 and Ladder Safety Cage 75 by means of clamping plates, SW 19.
7. Attach bottom-most ladder to the vertically-positioned element.

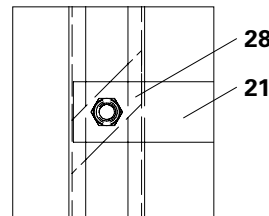

Fig. A3.12



Secure ladder safety cage above and below the ladder joint.

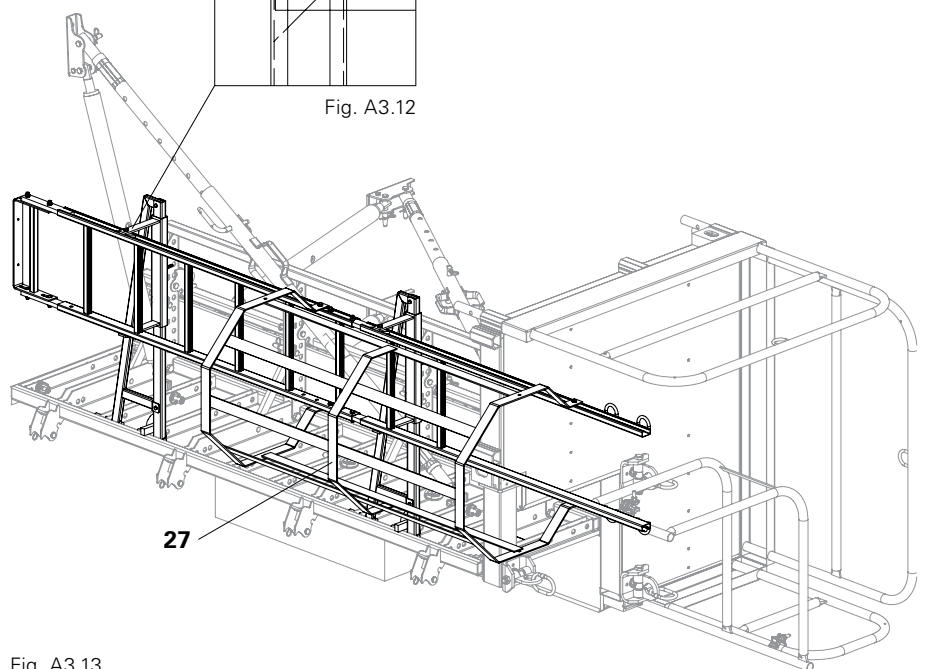

Fig. A3.13

## Placing the Formwork



**Check stability.**



Always install the element unit with the concreting platform first. Bottom-extended / extended elements can only be installed as an element unit. Locating boards (30) facilitate formwork adjustment.

### Formwork half with concreting platform

1. Attach 3-sling lifting gear to the crane eyes of the concreting platform, align formwork and then transport to the place of use.  
(Fig. A4.01)
2. Position formwork at right angles in the area of operations.
3. Secure with push-pull props and kicker braces, e.g. using PERI Anchor Bolt 14/20 x 130 or equivalent.
4. Check stability and align.
5. Detach lifting gear.  
(Fig. A4.02)

⇒ **The first formwork half is now in position.**

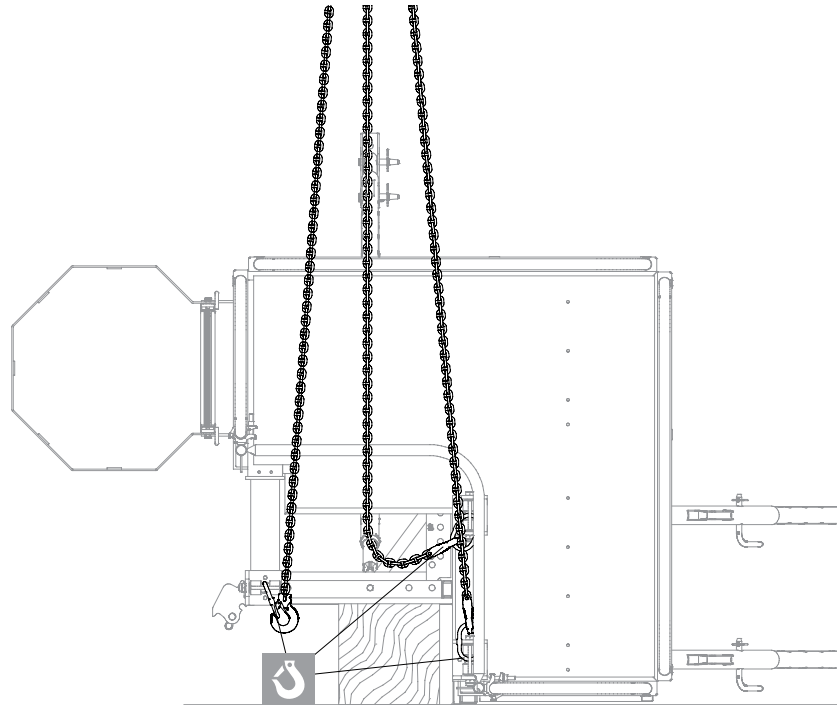

Fig. A4.01

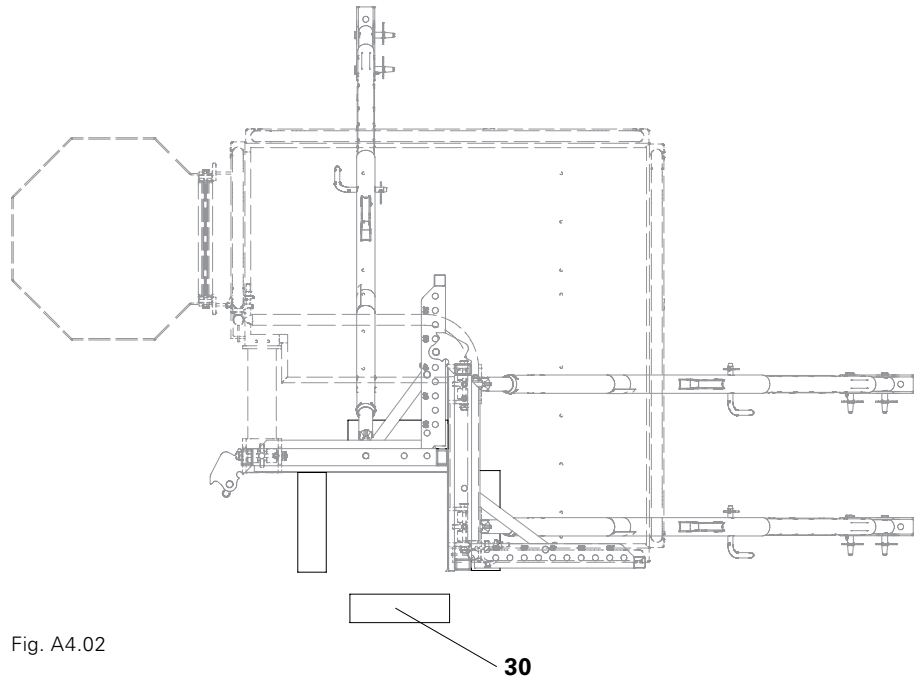

Fig. A4.02

## Closing the Formwork

1. Assemble second unit and attach to the previously erected formwork using bolts  $\text{Ø } 20 \times 140$  and cotter pins 4/1 (1.5). Take into account the cross-section!
2. Mark out QUATTRO QR Frame Spanner (2) using the provided bolts  $\text{Ø } 20 \times 140$  (1.5).
  - Position of the Frame Spanner = size of column - 5 cm.
  - Example: column = 35 cm, Frame Spanner = 30 cm. (Fig. A4.03)
3. Swing out QUATTRO QR Frame Spanner over the fastening straps on the adjacent element and tighten by means of the wingnuts (2.1). (Fig. A4.04)

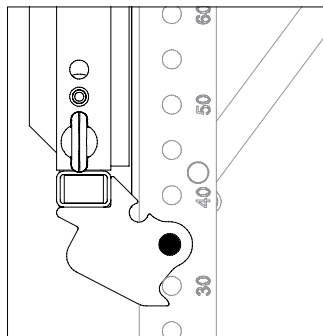

Fig. A4.03a

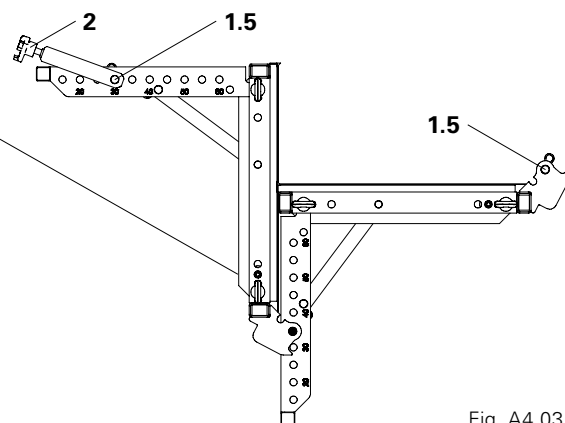

Fig. A4.03.

The right angle adjusts itself automatically through the tensioning.

(Fig. A4.04 is shown here without the concreting platform).



The stamped measurements in the perforated waler indicate the column cross-section. (Fig. A4.03a)

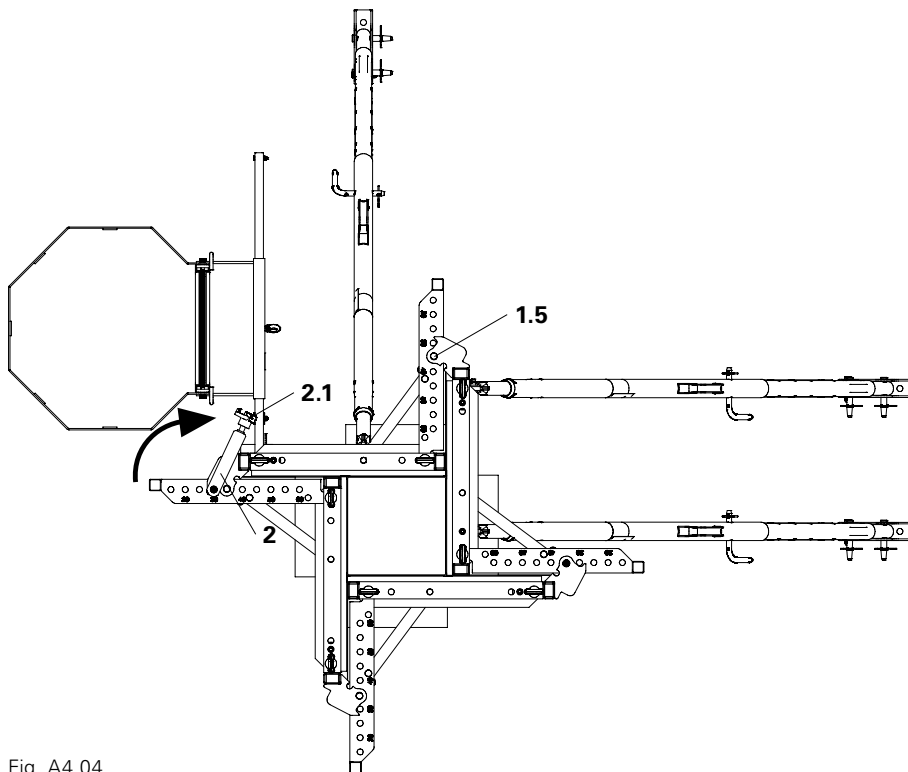

Fig. A4.04

## Striking

1. Loosen QUATTRO QA Frame Spanner (2), remove locking pins  $\text{Ø } 20 \times 140$  (6), fold up element with the QUATTRO QA Frame Spanner and stabilise the opened position by means of the locking pins  $\text{Ø } 20 \times 140$  (6) .(Fig. A5.01)
2. Continue to open the unit until the second element is released from the concrete.
3. Stabilise the unit in the opened position using the locking pins  $\text{Ø } 20 \times 140$  (6).
4. Secure the complete formwork to the crane.
5. Release push-pull props RS and remove the complete unit from the concrete.

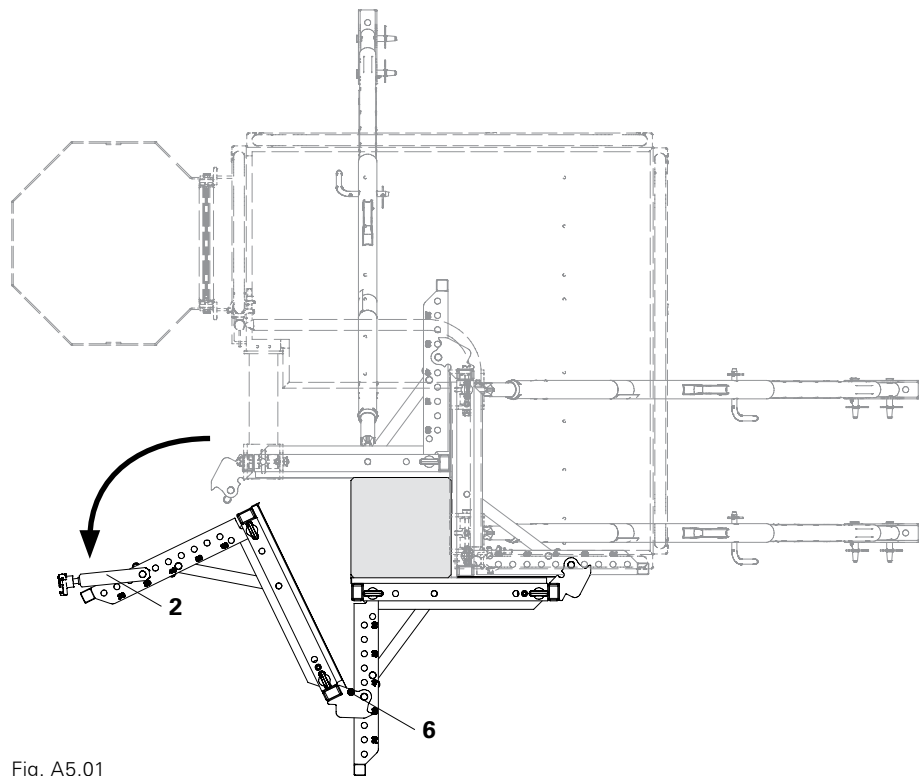

Fig. A5.01



The push-pull props RS remain attached and the moving process takes place using one crane lift.

## Moving by Crane

1. Attach lifting gear to the 3 crane eyes on the concreting platform (13).
2. Remove base plates of the push-pull props RS and kickers AV from the ground.
3. Position formwork for cleaning and secure.(Fig. A5.02)

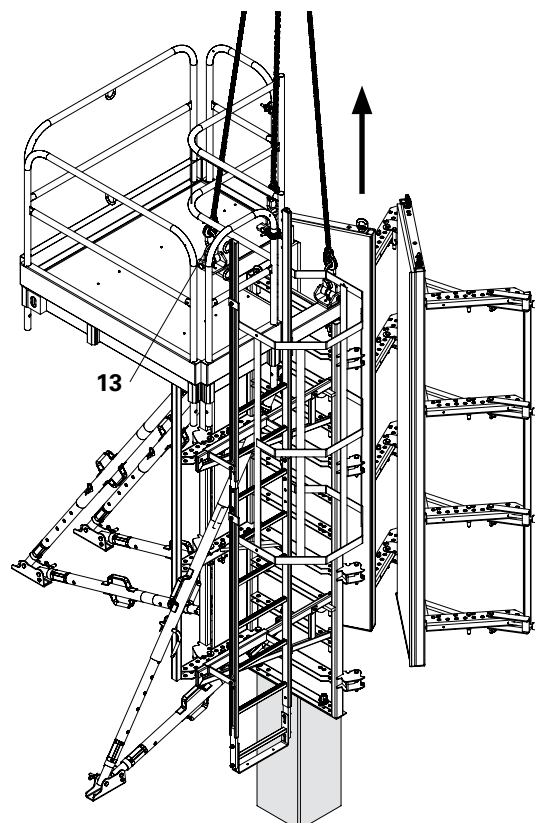

Fig. A5.02



**Formwork up to a max. height of 3.50 m may be moved by means of the transportation wheels.**

## Moving with Transportation Wheel

1. Mount four transportation wheels QUATTRO (7) on the closed formwork. The tube supports of the eccentric plate (7.1) are pointing upwards. (Fig. A5.03 + A5.03a)
2. Loosen the push-pull props and open formwork until the second unit is released from the concrete. Secure with bolt  $\varnothing 20 \times 140$ . (Fig. A5.04)
3. Release the base plate fixings and press the eccentric plate downwards.
  - Important: pay attention to the order! Wheel 1 - 4. (Fig. A5.04)
  - The formwork is raised and the tube supports are in a horizontal position. (Fig. A5.05)
  - Use a scaffold tube or tie rod. (Fig. A5.05)
4. Retract formwork, move, re-position formwork at next place of use and then close.
5. Press eccentric plate (7.1) upwards. The formwork is lowered and the tube supports are pointing upwards. (Fig. A5.06)
6. Fix base plates.

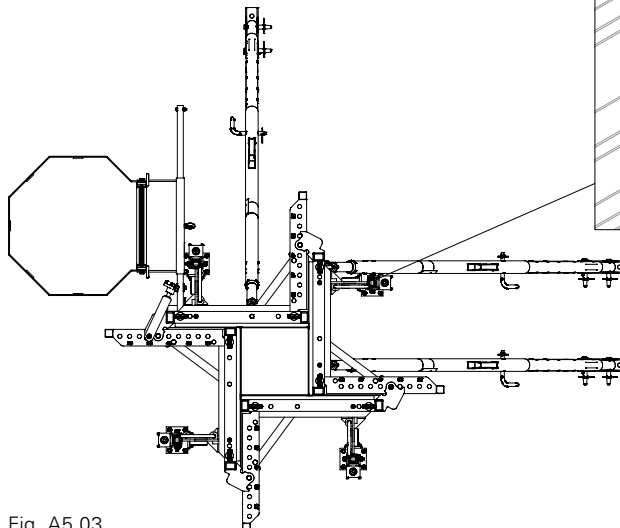

Fig. A5.03

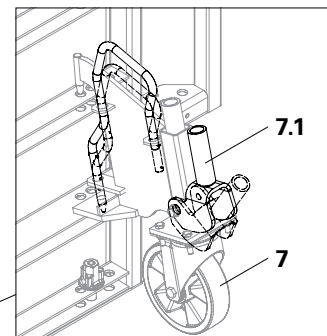

Fig. A5.03a

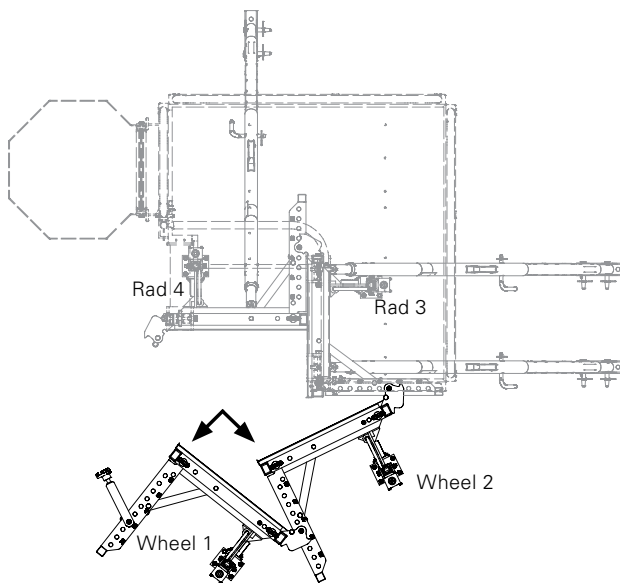

Fig. A5.04

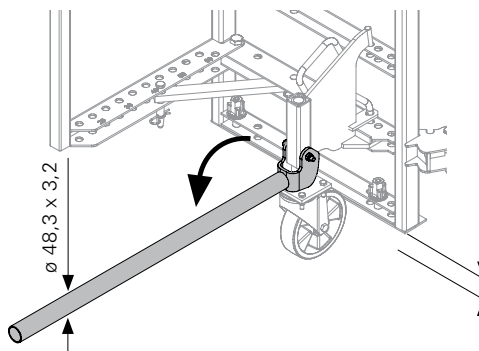

Fig. A5.05

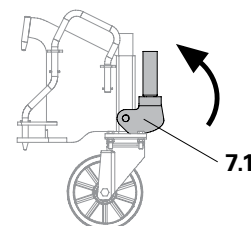

Fig. A5.06

# A6 Adjusting the Column Cross-Section

The cross-section can be adjusted if the formwork has been extended at the top and bottom, and with concreting platform. The locking pins  $\varnothing 20 \times 140$  (6) must always be inserted between the units (1)+(2) and (3)+(4).

## Moving with A

Attach unit (1) to the crane.  
Units (2-4) remain in position.

## Moving with B

Attach unit (1+2) to the crane.  
Units (3+4) remain in position.

## Moving with C

Attach unit (4) to the crane.  
Units (2-3) remain in position.

1. Release bolts  $\varnothing 20 \times 140$  (1.5) between the elements.
2. Position Frame Spanner according to the new cross-section.
3. Set out by means of bolts  $\varnothing 20 \times 140$  (1.5).  
(Fig. A6.01 + A6.01a)
4. Push elements QUATTRO QA (2) until new cross-section has been reached.  
(Fig. A6.01b)

Position of the Frame Spanner  
QUATTRO QA = size of column – 5 cm.  
Example: column = 35 cm,  
frame spanner = 30 cm.

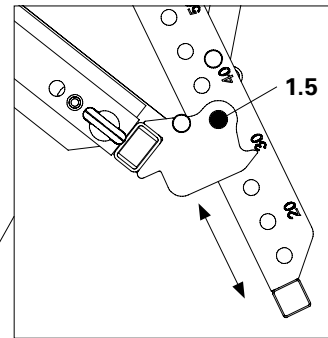

Fig. A6.01a

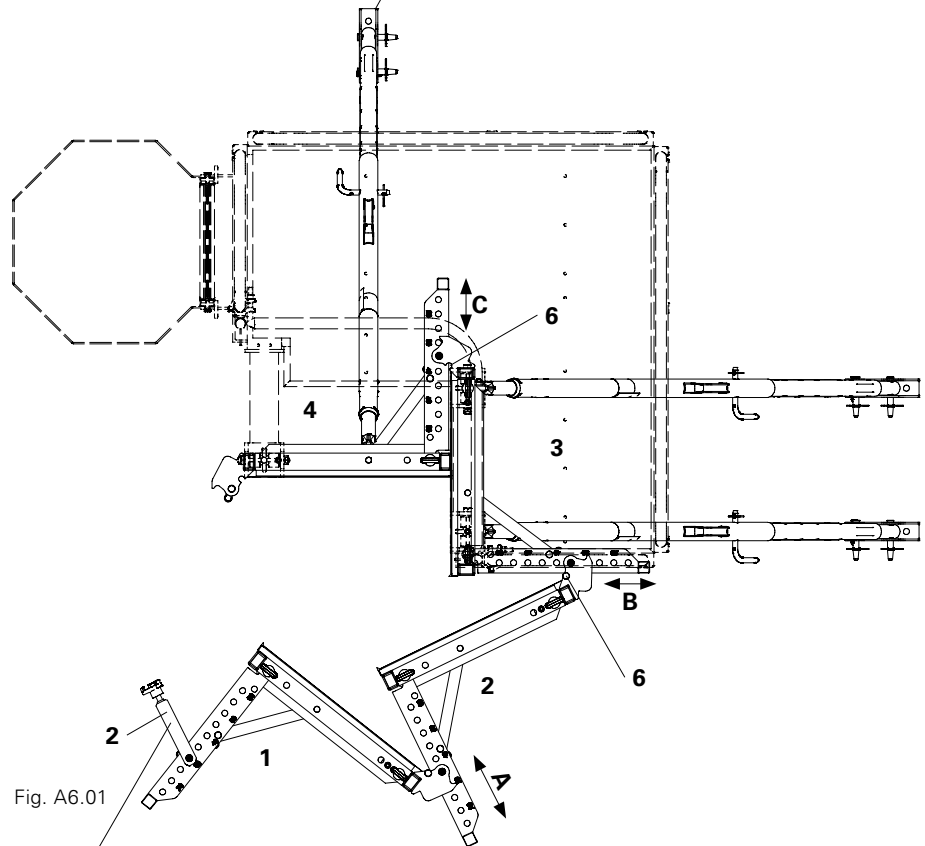

Fig. A6.01

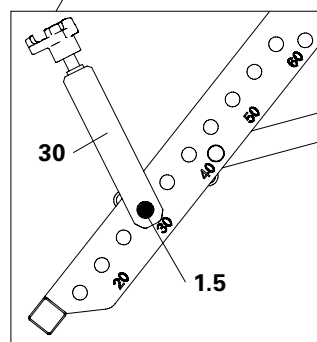

Fig. A6.01b



Item no.	Weight kg
109926	199.000

## QUATTRO Frame QES 350

Column Panel with 20 mm plywood, screwed on from behind. For cross-sections in 5-cm-increments from 20 x 20 cm to 60 x 60 cm. Eye bolt as load-bearing point and for extensions. Without chamfer strip.

### Complete with

- 2 pc. 724812 Stair Tower Eye Bolt M20 x 110, galv.
- 2 pc. 710045 Nut DIN 557-4 M20, galv.
- 13 pc. 105400 Pin Ø 20 x 140, galv.
- 13 pc. 018060 Cotter Pin 4/1, galv.
- 1 pc. 037550 Base Plate QUATTRO QB

### Technical Data

Permissible load-bearing point capacity 1.0 t.

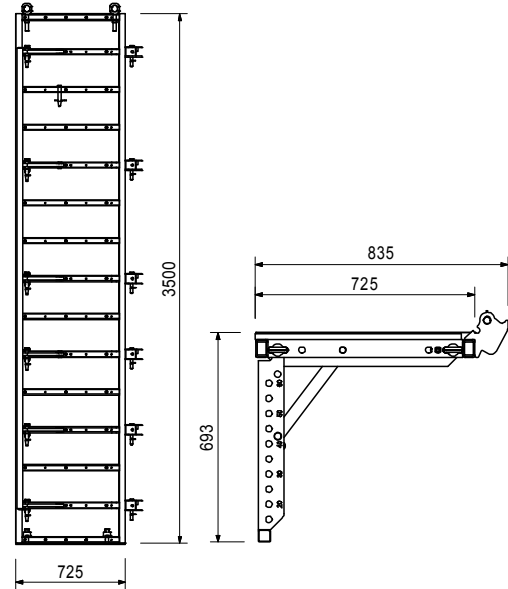
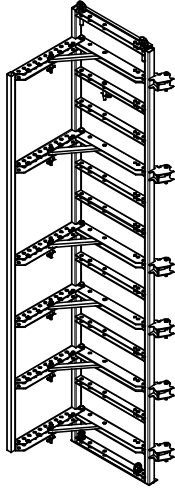

109925	152.000
--------	---------

## QUATTRO Frame QES 275

Column Panel with 20 mm plywood, screwed on from behind. For cross-sections in 5-cm-increments from 20 x 20 cm to 60 x 60 cm. Eye bolt as load-bearing point and for extensions. Without chamfer strip.

### Complete with

- 2 pc. 724812 Stair Tower Eye Bolt M20 x 110, galv.
- 2 pc. 710045 Nut DIN 557-4 M20, galv.
- 9 pc. 105400 Pin Ø 20 x 140, galv.
- 9 pc. 018060 Cotter Pin 4/1, galv.
- 1 pc. 037550 Base Plate QUATTRO QB

### Technical Data

Permissible load-bearing point capacity 1.0 t.

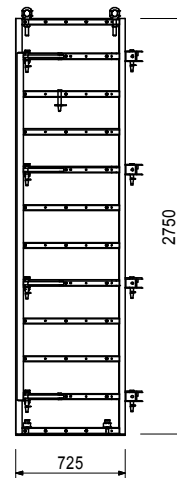
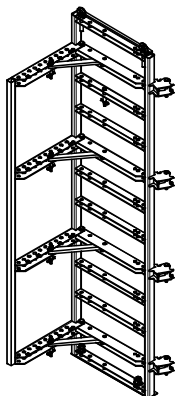



Item no.	Weight kg
109924	71.100

### QUATTRO Frame QES 125

Column Panel with 20 mm plywood, screwed on from behind. For cross-sections in 5-cm-increments from 20 x 20 cm to 60 x 60 cm. Eye bolt as load-bearing point and for extensions. Without chamfer strip.

### Complete with

- 2 pc. 724812 Stair Tower Eye Bolt M20 x 110, galv.
- 2 pc. 710045 Nut DIN 557-4 M20, galv.
- 5 pc. 105400 Pin Ø 20 x 140, galv.
- 5 pc. 018060 Cotter Pin 4/1, galv.

### Technical Data

Permissible load-bearing point capacity 1.0 t.

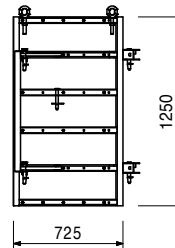
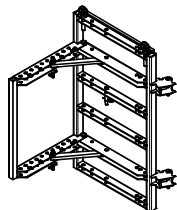

109923	31.200
--------	--------

### QUATTRO Frame QES 50

Column Panel with 20 mm plywood, screwed on from behind. For cross-sections in 5-cm-increments from 20 x 20 cm to 60 x 60 cm. Eye bolt as load-bearing point and for extensions. Without chamfer strip.

### Complete with

- 2 pc. 724812 Stair Tower Eye Bolt M20 x 110, galv.
- 2 pc. 710045 Nut DIN 557-4 M20, galv.
- 2 pc. 105400 Pin Ø 20 x 140, galv.
- 2 pc. 018060 Cotter Pin 4/1, galv.

### Technical Data

Permissible load-bearing point capacity 1.0 t.

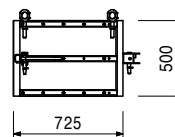
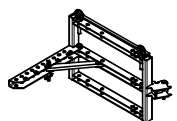

105448	0.665
037610	0.520
037600	0.230
037590	0.100

### Chamfer Strips QDL

#### Chamfer Strip QDL 350

#### Chamfer Strip QDL 275

#### Chamfer Strip QDL 125

#### Chamfer Strip QDL 50

Plastic chamfer strip with nailing panel. Edge length 15 x 15 mm.

### L

3500

2750

1250

500

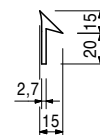
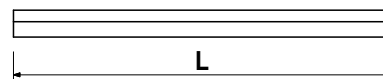
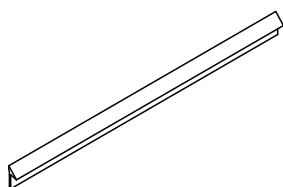

037550	3.240
--------	-------

### Base Plate QUATTRO QB

For protecting the plywood formlining against damage.

### Complete with

- 2 pc. 030130 Cam Nut DW 15, galv.

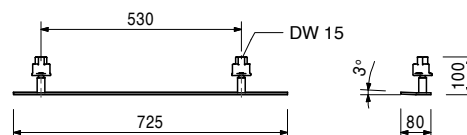
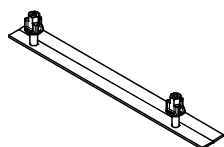

Item no.	Weight kg
037540	2.370

**Frame Spanner QUATTRO QA**  
For bracing QUATTRO Column Panels.  
Only required at a column corner.

**Note**  
Required no. of pieces:  
h = 3.50 m 6 pieces, h = 2.75 m 4 pieces  
h = 1.25 m 2 pieces, h = 0.50 m 1 piece

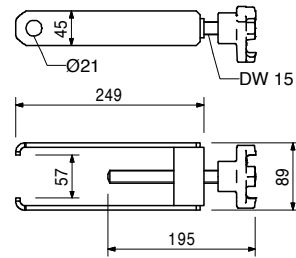
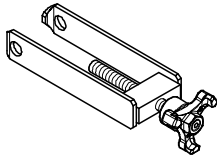

Item no.	Weight kg
105400	0.330
018060	0.014

Accessories  
**Pin Ø 20 x 140, galv.**  
**Cotter Pin 4/1, galv.**

037530	1.130
--------	-------

**Brace Connector QUATTRO QR**  
For connecting push-pull props and kicker braces  
to QUATTRO and LICO Panels.

**Complete with**  
1 pc. 027170 Pin Ø 16 x 42, galv.  
1 pc. 018060 Cotter Pin 4/1, galv.

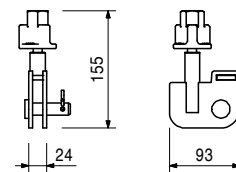
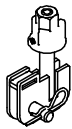

724500	0.098
--------	-------

**Bolt Ø 20 x 42, QUATTRO, galv.**  
For different connections.

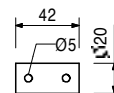

018060	0.014
--------	-------

Accessories  
**Cotter Pin 4/1, galv.**

105400	0.330
--------	-------

**Pin Ø 20 x 140, galv.**  
For different connections.

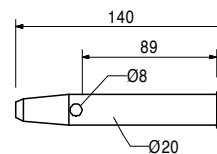
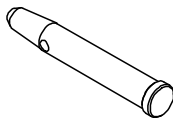

018060	0.014
--------	-------

Accessories  
**Cotter Pin 4/1, galv.**

# QUATTRO Column Formwork

Item no.	Weight kg
018060	0.014

**Cotter Pin 4/1, galv.**

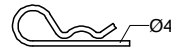

105791	16.900
--------	--------

## Transportation Wheel QUATTRO

For moving completely assembled QUATTRO Column Formwork. Always use 4 pieces per column.

## Technical Data

Permissible load-bearing capacity 500 kg.

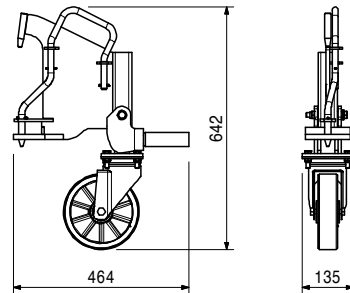
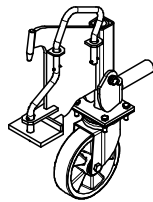

103391	4.890
--------	-------

## Ladder Connector QUATTRO

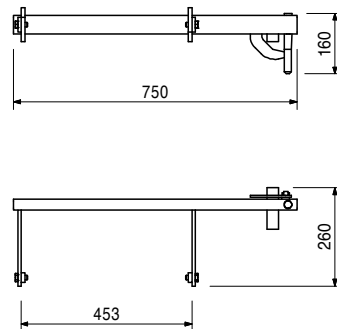
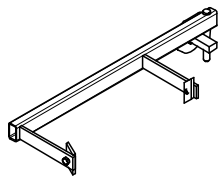

127260	9.240
--------	-------

## QUATTRO Ladder Connector-2

For connecting ladders to QUATTRO Column Panels.

## Complete with

2 pc. 710266 Bolt ISO 4017 M12 x 25-8.8, galv.  
2 pc. 701763 Clamping Plate FI 25 x 10 x 90

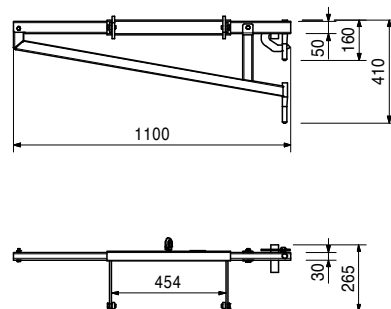
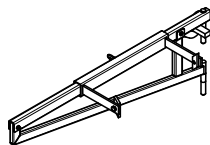

# QUATTRO Column Formwork



Item no.	Weight kg
037400	123.000

## Concreting Platform, compl.

Working and concreting platform for TRIO, RAPID and QUATTRO Column Formwork.

## Complete with

- 1 pc. 037410 Concreting Landing, Alu
- 2 pc. 037420 Platform Guardrail 52, galv.
- 2 pc. 037430 Platform Guardrail 134, galv.
- 3 pc. 037440 Crane Hook Concreting Platform

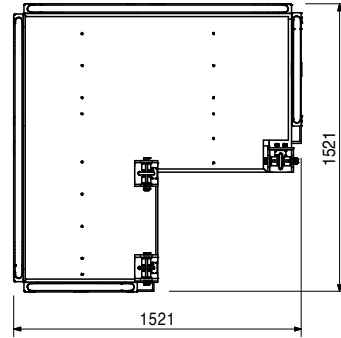
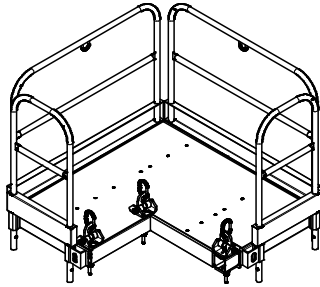

037410	51.400
--------	--------

## Concreting Landing, Alu

Adjusts continuously to all column cross-sections up to max. 60 x 60 cm. Attachment is carried out using the crane eye of the concreting platform.

## Technical Data

Permissible load 150 kg/m<sup>2</sup>.

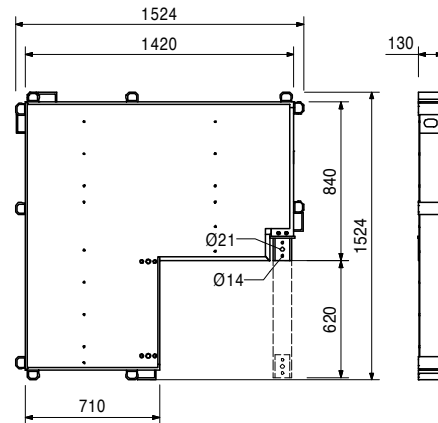
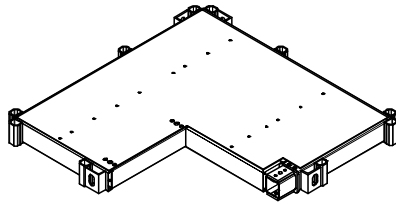

037420	10.200
--------	--------

## Platform Guardrail 52, galv.

As guardrail for PERI Concreting Platforms. Locks in place automatically.

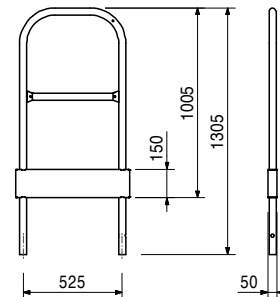
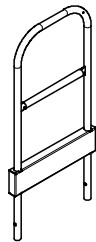

# QUATTRO Column Formwork



Item no.	Weight kg
037430	17.100

## Platform Guardrail 134, galv.

As guardrail for PERI Concreting Platforms. Locks in place automatically.

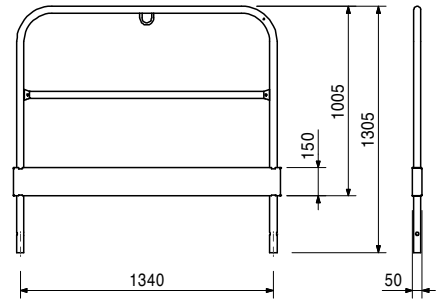
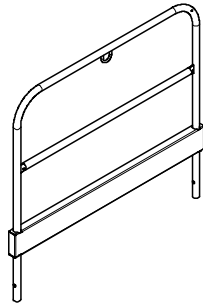

115352	15.300
--------	--------

## Platform Front Guardrail 86/86

As guardrail for PERI Concreting Platforms towards the column. Mounted with Screw-on Coupler.

### Note

Wrench size SW 19.

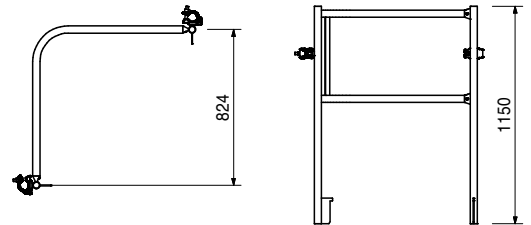
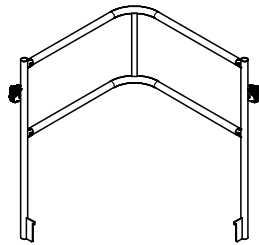

037440	5.640
--------	-------

## Crane Hook Concreting Platform

For assembling the concreting landing to the TRIO, RAPID and QUATTRO column frames.

### Note

Follow Instructions for Assembly and Use!

### Technical Data

Permissible load-bearing capacity 1.0 t.

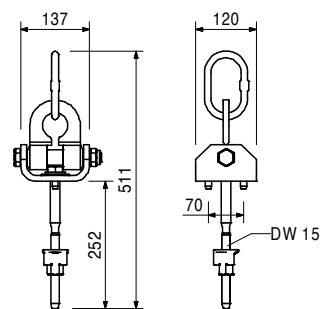
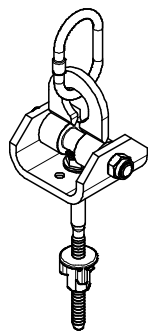

051460	2.180
--------	-------

## Ladder Base, galv.

As bottom ladder connection and for securing ladders against sliding on the scaffold decks.

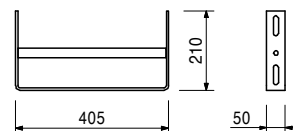
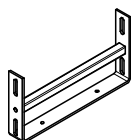

# QUATTRO Column Formwork



Item no.	Weight kg
051410	11.700

**Ladder 180/6, galv.**  
As access for PERI Formwork Systems.

**Complete with**  
4 pc. 710224 Bolt ISO 4017 M12 x 40-8.8, galv.  
4 pc. 710381 Nut ISO 7042 M12-8, galv.

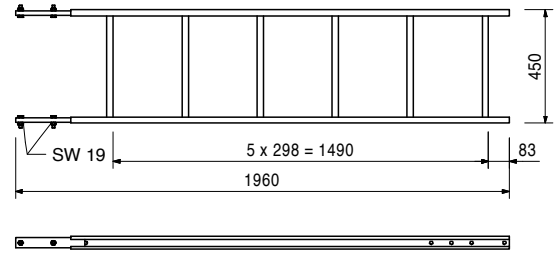
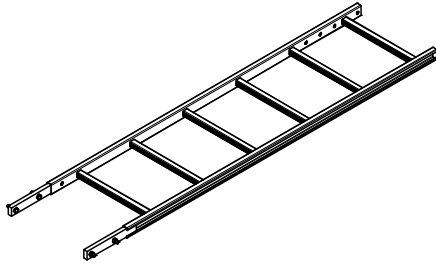

103724	10.400
--------	--------

**End Ladder 180/2, galv.**  
As access for PERI Formwork Systems.

**Complete with**  
4 pc. 710224 Bolt ISO 4017 M12 x 40-8.8, galv.  
4 pc. 710381 Nut ISO 7042 M12-8, galv.

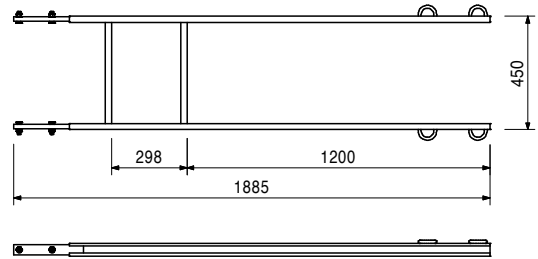
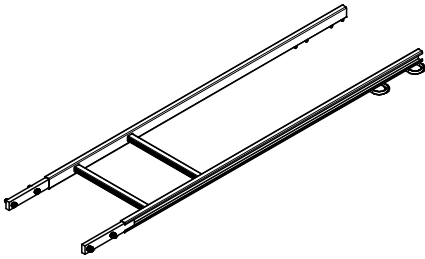

104132	15.600
051450	25.200

**Lader Safety Cages, galv.**  
**Ladder Safety Cage 75, galv.**  
**Ladder Safety Cage 150, galv.**  
Ladder safety cage for PERI Access Ladders.

**Complete with**  
4 pc. 710266 Bolt ISO 4017 M12 x 25-8.8, galv.  
4 pc. 701763 Clamping Plate FI 25 x 10 x 90

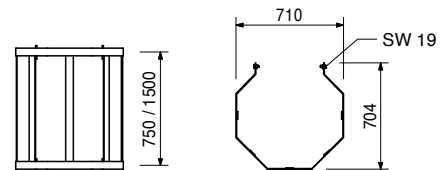
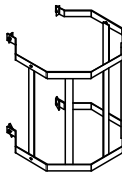

103718	0.684
--------	-------

**Ladder Hook, galv.**  
For adjusting the bottom ladder.  
Always use in pairs.

**Complete with**  
2 pc. 710266 Bolt ISO 4017 M12 x 25-8.8, galv.  
2 pc. 710381 Nut ISO 7042 M12-8, galv.

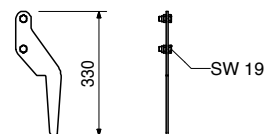

# QUATTRO Column Formwork



Item no.	Weight kg
117466	10.600

## Push-Pull Prop RS 210, galv.

Extension length  $l = 1.30 - 2.10$  m.  
For aligning PERI Formwork Systems and precast concrete elements.

### Note

Permissible load see PERI Design Tables.

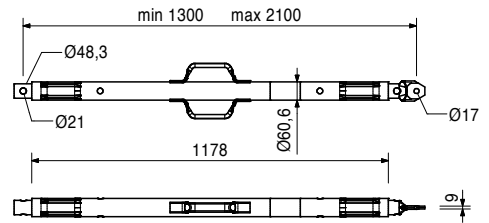
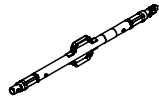

118238	12.100
--------	--------

## Push-Pull Prop RS 260, galv.

Extension length  $l = 2.30 - 2.60$  m.  
For aligning PERI Formwork Systems and precast concrete elements.

### Note

Permissible load see PERI Design Tables.

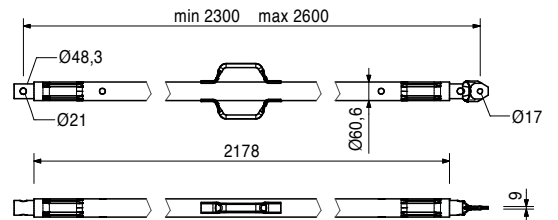
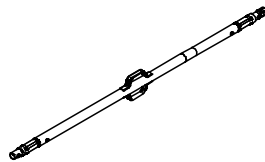

117467	15.500
--------	--------

## Push-Pull Prop RS 300, galv.

Extension length  $l = 1.90 - 3.00$  m.  
For aligning PERI Formwork Systems and precast concrete elements.

### Note

Permissible load see PERI Design Tables.

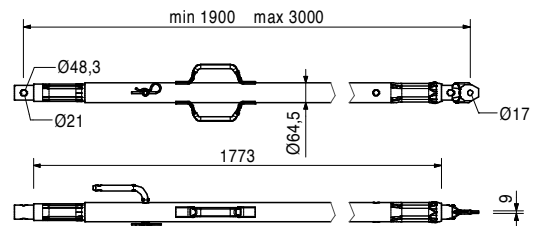
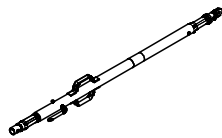

117468	23.000
--------	--------

## Push-Pull Prop RS 450, galv.

Extension length  $l = 2.80 - 4.50$  m.  
For aligning PERI Formwork Systems and precast concrete elements.

### Note

Permissible load see PERI Design Tables.

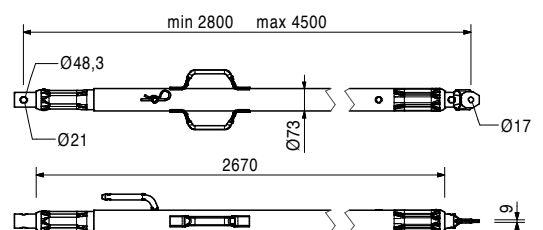
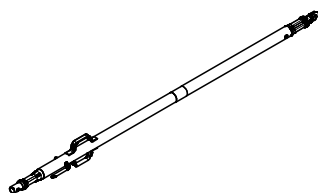

# QUATTRO Column Formwork



Item no.	Weight kg
117469	39.900

**Push-Pull Prop RS 650, galv.**  
 Extension length  $l = 4.30 - 6.50$  m.  
 For aligning PERI Formwork Systems and precast concrete elements.

**Note**  
 Permissible load see PERI Design Tables.

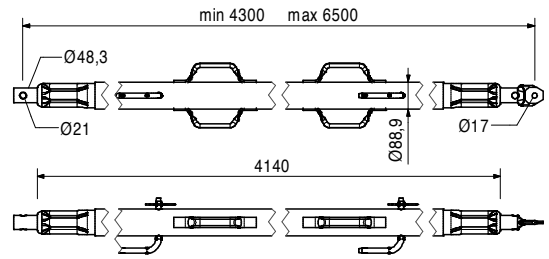
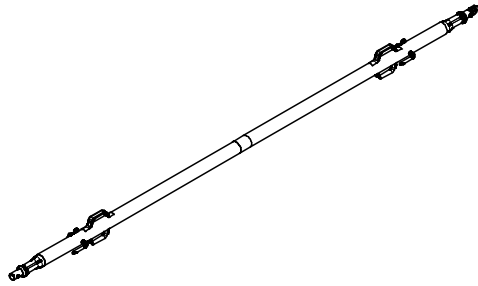

028990	115.000
--------	---------

**Push-Pull Prop RS 1000, galv.**  
 Extension length  $l = 6.40 - 10.00$  m.  
 For aligning PERI Formwork Systems.

**Note**  
 Permissible load see PERI Design Tables.

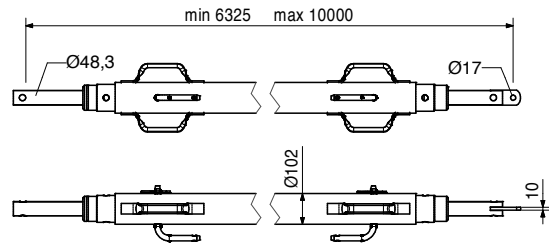
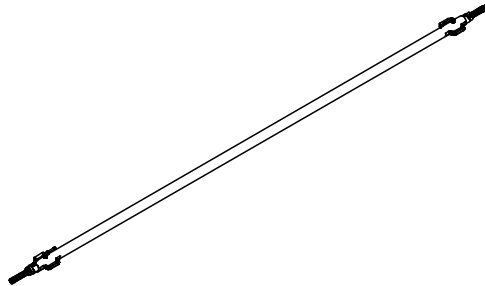

103800	271.000
--------	---------

**Push-Pull Prop RS 1400, galv.**  
 Extension length  $l = 6.40 - 14.00$  m.  
 For aligning PERI Formwork Systems.

**Note**  
 Permissible load see PERI Design Tables.  
 Chain can be operated from bottom.

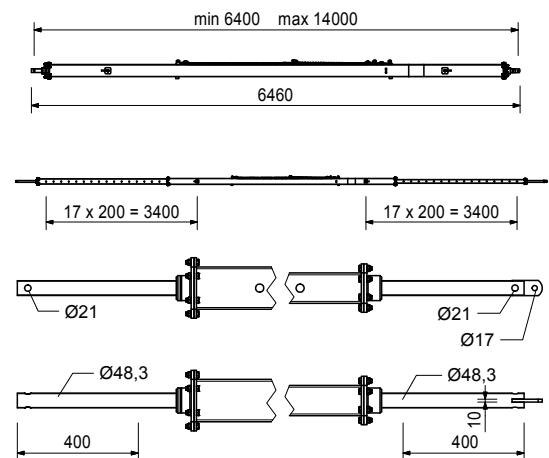
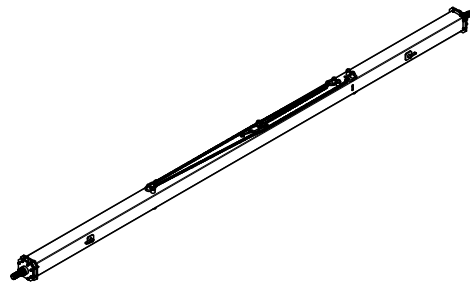



Item no.	Weight kg
126666	3.070

**Base Plate-3 for RS 210 - 1400**

For assembly of Push-Pull Props RS 210, 260, 300, 450, 650, 1000 and 1400.

**Complete with**

- 2 pc. 105400 Pin Ø 20 x 140, galv.
- 2 pc. 018060 Cotter Pin 4/1, galv.
- 1 pc. 113063 Bolt ISO 4014 M12 x 80-8.8, galv.
- 1 pc. 113064 Hex Nut ISO7042-M12-8-G, galv.

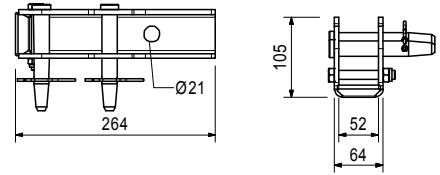
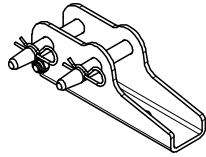

Accessories

124777	0.210
--------	-------

**Anchor Bolt PERI 14/20 x 130**

102018	4.880
--------	-------

**Base Plate-2 for RS 1000/1400, galv.**

For assembly of Push-Pull Props RS 210, 260, 300, 450, 650, 1000, 1400 and Heavy Duty Spindles.

**Complete with**

- 2 pc. 105400 Pin Ø 20 x 140, galv.
- 2 pc. 018060 Cotter Pin 4/1, galv.

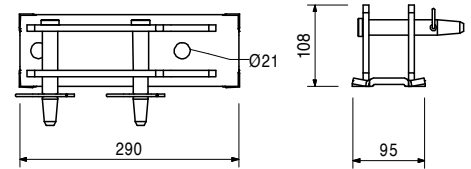
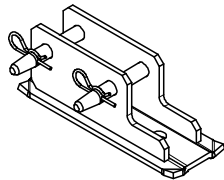

117343	3.250
--------	-------

**Base Plate-2 for RS 210 - 1400, galv.**

For assembly of Push-Pull Props RS 210, 260, 300, 450, 650, 1000 and 1400.

**Complete with**

- 2 pc. 105400 Pin Ø 20 x 140, galv.
- 2 pc. 018060 Cotter Pin 4/1, galv.

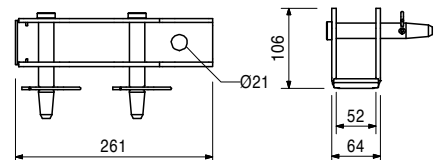
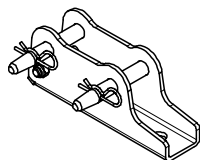

Accessories

124777	0.210
--------	-------

**Anchor Bolt PERI 14/20 x 130**

028010	17.900
--------	--------

**Push-Pull Prop RSS I**

Extension length l = 2.05 – 2.94 m.  
For aligning PERI Formwork Systems.

**Note**

Permissible load see PERI Design Tables.

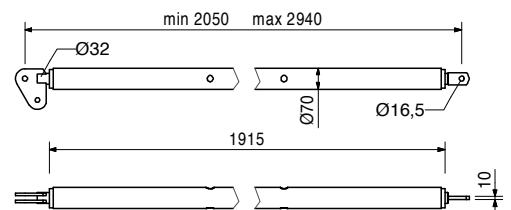
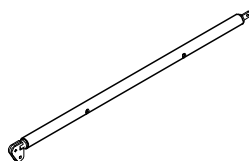

Accessories

113397	1.600
--------	-------

**Spindle Handle RSS / AV**

Item no.	Weight kg
113397	1.600

### Spindle Handle RSS / AV

Spindle handle for screwing on Push-Pull-Props RSS I, RSS II and Kickers AV 210 and AV RSS III.

### Complete with

2 pc. 722342 Screw ISO 4017 M8 x 25-8.8, galv.  
2 pc. 711071 Nut ISO 7042 M8-8, galv.

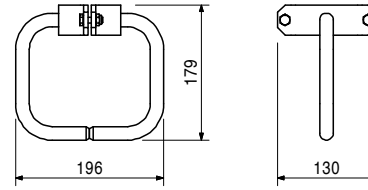
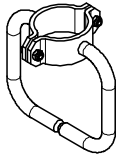

028020	22.000
--------	--------

### Push-Pull Prop RSS II

Extension length  $l = 2.91 - 3.80$  m.  
For aligning PERI Formwork Systems.

### Note

Permissible load see PERI Design Tables.

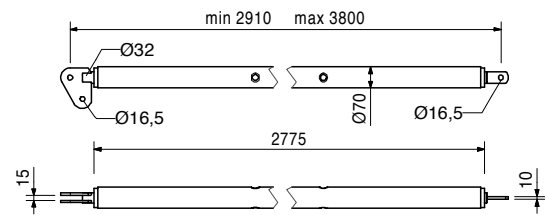
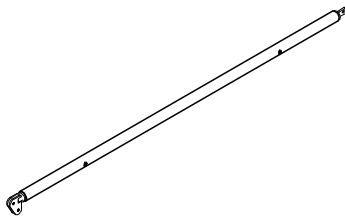

Accessories

113397	1.600
--------	-------

### Spindle Handle RSS / AV

028030	38.400
--------	--------

### Push-Pull Prop RSS III

Extension length  $l = 4.60 - 6.00$  m.  
For aligning PERI Formwork Systems.

### Note

Permissible load see PERI Design Tables.

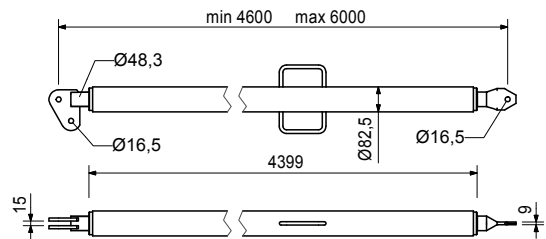
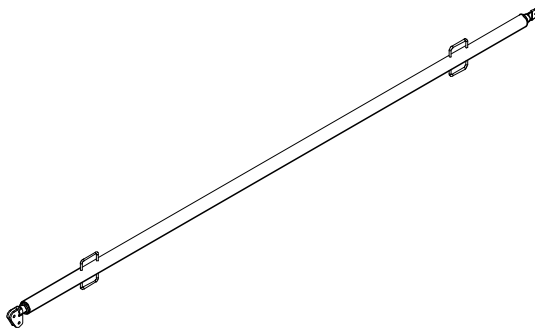

106000	1.820
--------	-------

### Base Plate-2 for RSS, galv.

For assembly of Push-Pull Props RSS.

### Complete with

1 pc. 027170 Pin  $\varnothing 16 \times 42$ , galv.  
1 pc. 018060 Cotter Pin 4/1, galv.

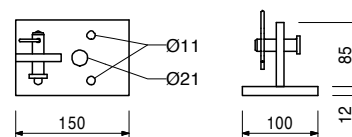
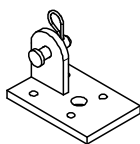

Accessories

124777	0.210
--------	-------

### Anchor Bolt PERI 14/20 x 130

# QUATTRO Column Formwork



Item no.	Weight kg
057087	3.510
057088	4.200

**Kicker AV**  
**Kicker AV 82**  
**Kicker AV 111**  
 For aligning PERI Formwork Systems.

min. L	max. L
500	820
790	1110

**Complete with**  
 1 pc. 027170 Pin Ø 16 x 42, galv.  
 1 pc. 018060 Cotter Pin 4/1, galv.

**Note**  
 Permissible load see PERI Design Tables.

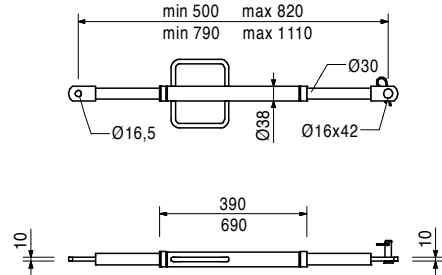
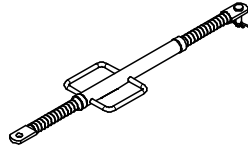

028110	4.850
--------	-------

**Kicker AV 140**  
 Extension length l = 1.08 – 1.40 m.  
 For aligning PERI Formwork Systems.

**Complete with**  
 1 pc. 027170 Pin Ø 16 x 42, galv.  
 1 pc. 018060 Cotter Pin 4/1, galv.

**Note**  
 Permissible load see PERI Design Tables.

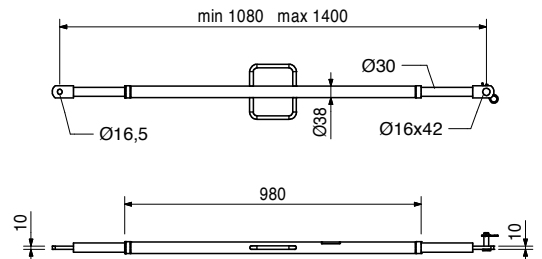
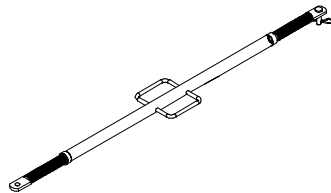

108135	12.900
--------	--------

**Kicker AV 210**  
 Extension length l = 1.28 – 2.10 m.  
 For aligning PERI Formwork Systems.

**Complete with**  
 1 pc. 027170 Pin Ø 16 x 42, galv.  
 1 pc. 018060 Cotter Pin 4/1, galv.

**Note**  
 Permissible load see PERI Design Tables.

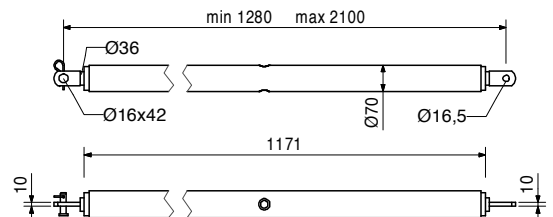
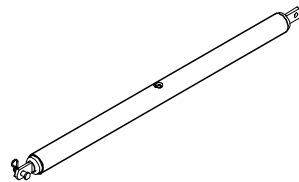

Accessories  
**Spindle Handle RSS / AV**

113397	1.600
--------	-------

Item no.	Weight kg
028120	17.000

### Kicker AV RSS III

Extension length  $l = 2.03 - 2.92$  m.  
For aligning PERI Formwork Systems.

### Complete with

1 pc. 027170 Pin  $\varnothing 16 \times 42$ , galv.  
1 pc. 018060 Cotter Pin 4/1, galv.

### Note

Permissible load see PERI Design Tables.

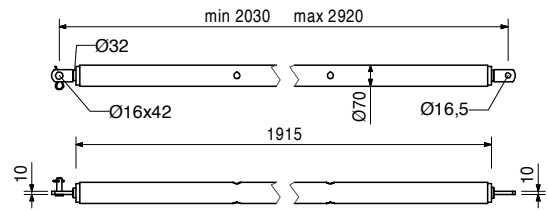
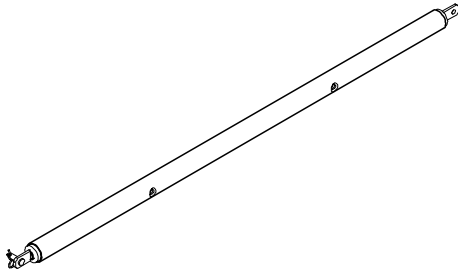

Item no.	Weight kg
113397	1.600

Accessories

### Spindle Handle RSS / AV

028080	2.970
--------	-------

### Connector Kicker/Push-Pull Prop, galv.

For connecting push-pull props and kicker braces to Main Beam HDT.

### Complete with

1 pc. 027170 Pin  $\varnothing 16 \times 42$ , galv.  
1 pc. 018060 Cotter Pin 4/1, galv.

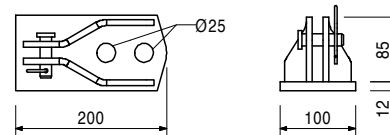
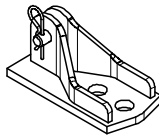

124777	0.210
--------	-------

### Anchor Bolt PERI 14/20 x 130

For temporary fixation to reinforced concrete structures.

### Note

See PERI Data Sheet!  
Drilling  $\varnothing 14$  mm.

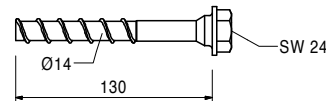
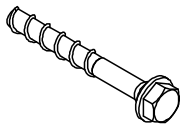



**The optimal System  
for every Project and  
every Requirement**



**Wall Formwork**



**Column Formwork**



**Slab Formwork**



**Climbing Systems**



**Bridge Formwork**



**Tunnel Formwork**



**Shoring Systems**



**Construction Scaffold**



**Facade Scaffold**



**Industrial Scaffold**



**Access**



**Protection Scaffold**



**Safety Systems**



**System-Independent  
Accessories**



**Services**



**PERI GmbH**  
**Formwork Scaffolding Engineering**  
 Rudolf-Diesel-Strasse 19  
 89264 Weissenhorn  
 Germany  
 Tel. +49 (0)7309.950-0  
 Fax +49 (0)7309.951-0  
 info@peri.com  
 www.peri.com

